

SEL-2411P

Pump Automation Controller



Proven reliability and performance in water and wastewater pump applications

- Simple, out-of-the-box configuration requires no software to set up—simply install and use in new and retrofit applications.
- Nonproprietary, SCADA-ready device uses standard protocols, including Modbus and DNP3 over Ethernet and serial interfaces.
- Customizable solution with no-charge configuration software.
- Standard ten-year, no-questions-asked warranty and free technical support ensure a low cost of ownership.





Overview

Intelligent Water/Wastewater Control and Monitoring

The SEL-2411P Pump Automation Controller is a reliable, economical solution to many challenges faced by the water and wastewater industry. The SEL-2411P addresses these challenges by:

- Avoiding pollutant discharge of lift stations or potable reservoir overflows with a reliable control system and operator notification.
- Increasing system and equipment visibility for efficient monitoring and troubleshooting.
- Providing secure and user-accessible programming to facilitate system customization and upgrades and expand functionality.

The SEL-2411P controls and monitors multiple pumps that perform liquid level control. It is designed for pump-up or pump-down applications, such as wells/reservoirs and lift stations. The SEL-2411P provides flexible I/O options, SELogic® control equations, multiple communications protocols, and simple SCADA integration.

The SEL-2411P can control constant-speed, variable-speed, and alternating pumps. Modes of operation include level control and manual (HAND).

The level control mode offers selectable pump-up and pump-down control for simplex, duplex, and triplex pumping applications. The mode is configurable to use a selectable lead/lag/standby configuration in a simple alternating operation. The SEL-2411P is compatible with analog level sensors, floats, or a combination of both. The fully configured controller allows you to operate pumps in standalone automatic mode, manually through the Hand-Off-Auto switches, and remotely through SCADA.

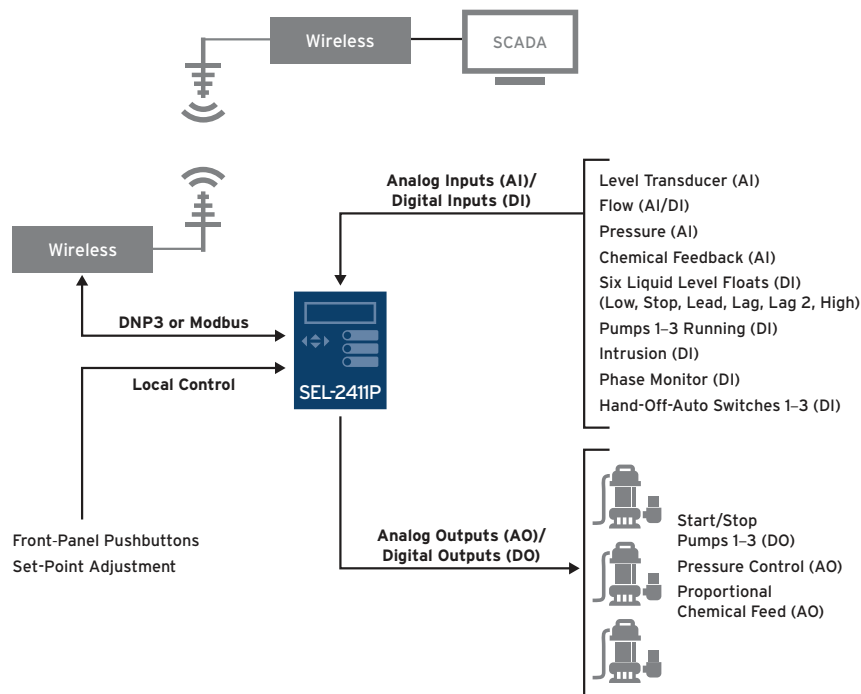

Key Features and Advantages

Highly Reliable

The SEL-2411P is the ideal controller for critical applications where controller failures are costly or damaging. It boasts a mean time between failures (MTBF) of over 900 years, meaning that for every 900 controllers deployed, you can expect one failure per year.

The reliability of the SEL-2411P ensures years of maintenance-free monitoring and operation while alerting operators to malfunctions and mitigating the damage. Sequence of Events (SOE) reports help you pinpoint problems and reduce trouble-shooting times.

Built for Unforgiving Environments

SEL's environmental testing ensures that every unit will perform in harsh water and wastewater environments. The SEL-2411P can withstand 15 g of vibration, 15 kV of electrostatic shock, and temperatures from -40° to $+85^{\circ}\text{C}$ (-40° to $+185^{\circ}\text{F}$). Additionally, the SEL-2411P has Class 1, Division 2 approval and comes standard with conformal coating to protect against atmospheres with corrosive gases, fumes, or liquids.

Interoperable and SCADA-Ready

The SEL-2411P provides Modbus and DNP3 protocols over Ethernet and serial interfaces for flexible SCADA communication using most existing or new communications infrastructure. You can use radio, cellular, and wired communications to integrate the SEL-2411P into an existing SCADA system. The preconfigured DNP3 map makes integration simple, and you can easily modify it for additional customization.

Customizable

Although the standard SEL-2411P is feature-rich, you can customize the controller with specific interlock, automation, alarming, and diagnostic features for your application. We provide no-charge configuration software, application guides, and nationwide support to help you customize the solution to meet your requirements.

Failover Control

The SEL-2411P can operate independently from a master SCADA control system. Upon communications failure, the SEL-2411P fails over to a predefined operation mode. It monitors floats for out-of-sequence operations and monitors level transducers to alarm and fail over to float switches in the event of a detectable transducer failure.

Flexible I/O Options

You can customize the SEL-2411P with a wide range of I/O option cards to fit many applications, like phase monitoring.

Diagnostics and Troubleshooting

The SEL-2411P buffers and time-stamps digital and analog changes using the DNP3 protocol. During communications failures, these data are stored and streamed back to the SCADA master to ensure data integrity. This lets you more accurately troubleshoot station operations. The SEL-2411P also provides pump reports for real-time pump status and provides SOE reports to help you efficiently troubleshoot issues.

Out-of-the-Box Solution

The SEL-2411P is quick and simple to install and set with easy-to-understand terminal labeling and preloaded settings. You can use the controller for multiple applications. The SEL-2411P offers specific functionality for simplex, duplex, and triplex applications in lift stations and well/reservoir applications. Features and functions include:

- Interactive, simple configuration—Answer as few as four questions using the Station Settings function to set the controller for simplex, duplex, or triplex operations.
- Pump alternation operation.
- Configurable failover modes for loss of analog-level transducer and loss of communication.
- Level control using a local or remote analog-level transducer and/or float switches.
- System-wide control and monitoring when combined with a master controller, also available from SEL.
- Local controls and HMI for set-point adjustment with or without SCADA.
- Local and SCADA diagnostic data to quickly identify maintenance issues.



The SEL-2411P makes exchanging or expanding I/O cards easy. Just detach the connectors and remove the rear cover.

SEL-2411P
MAIN ST L/S 101

Date: 12/09/2019 Time: 10:59:54.481
Time Source: Internal

	PUMP 1	PUMP 2	PUMP 3
Pump status	Ready	Ready	Running
Starting stage call	Lag2	Lag 1	Lead
2 Hour start count	19	18	19
24 hour start count	229	228	229
48 hour start count	457	456	457
Total start count	4275	4275	4274
2 Hour run time (min)	35.9	33.0	33.7
24 Hour run time (min)	415.7	405.2	412.5
48 Hour run time (min)	826	814.8	825.1
Total run time (hr)	128.38	128.03	127.95
Last Start Time (min)	3	6	1
Last Reset Date	11/18/19	11/18/19	11/18/19
Last Reset Time	20:16:02	20:16:18	20:16:24
	STAGE 1	STAGE 2	STAGE 3
Stage status	Called	Ready	Ready
Cycle Run Time (sec)	86	0	0
Level Value Input	3.07		
Flow Value Input -	1518.66		

=>SER 10

SEL-2411P
MAIN ST L/S 101

Date: 12/09/2019 Time: 10:59:59.506
Time Source: Internal

Serial No = 3190240059
CID = 78F9

FID = SEL-2411P-X034-V0-Z002008-D20191107

#	DATE	TIME	ELEMENT	STATE
10	12/11/19	10:56:57.1758	LEAD_IN	Deasserted
9	12/11/19	10:58:09.5758	STOP_IN	Deasserted
8	12/11/19	10:58:09.9683	PUMP1	Deasserted
7	12/11/19	10:58:15.1758	PUMPIRUN	Deasserted
6	12/11/19	10:58:15.5678	STOP_IN	Asserted
5	12/11/19	10:58:27.5638	LEAD_IN	Asserted
4	12/11/19	10:58:28.1678	PUMP3	Asserted
3	12/11/19	10:58:30.6638	PUMP3RUN	Asserted
2	12/11/19	10:58:46.7758	LEAD_IN	Deasserted
1	12/11/19	10:59:59.1758	STOP_IN	Deasserted

Motor report with SOE report.



Specifications

General	
Power Supply	24–48 Vdc Option Range: 18–60 Vdc 110–250 Vdc, 110–240 Vac Option Range: 85–275 Vac, 85–264 Vdc
Power Consumption	<40 VA (ac); <15 W (dc)
Operating Temperature	IEC performance rating: –40° to +85°C (–40° to +185°F) Class I, Div. 2 rating: –20° to +40°C (–4° to +104°F)
Certifications	UL CSA Class 1, Div. 2
Ingress Protection Rating	IP65 when enclosed in panel IP20 for rear terminals
Dimensions	Height: 144 mm (5.67 in) Width: 192 mm (7.56 in) Depth: 147.4 mm (5.8 in)
I/O Plug-In Cards	Pre-installed cards: one 14 digital input (DI) card and one 4 DI/4 fast high-current hybrid digital output (DO) card Two additional optional cards chosen from the following: 14 DI card, 8 analog input (AI) card, 4 AI/4 analog output (AO) card, or 3 ac voltage input (AVI) phase monitor card
Communication	Two 10/100 Ethernet ports and two EIA-232 ports (front and back)
Protocols	Modbus RTU, Modbus TCP, DNP3, DNP3 LAN/WAN, MIRRORRED BITS®, SEL ASCII, and binary communications
Station Settings	Interactive, simple configuration—Answer as few as four questions using the Station Settings function to automatically set up the controller for your applications. Refer to the SEL-2411P instruction manual for supported applications.
Mount	Panel mount

Application Specifications

Number of Pumps Controlled	Up to 4
Pump Modes	Level control (pump-up/pump-down selectable) Manual (HAND)
Alternation Modes	Automatic Fixed User-defined
Operation Modes	Single pump (well controller) Duplex pump controller Triplex station Triplex jockey Triplex high service
Performance Monitoring (Pump Reports)	Run time for the last 2 hr, 24 hr, and 48 hr and total run time per pump Pump start counts for the last 2 hr, 24 hr, and 48 hr and total starts per pump
Fault Detection	Loss of CT, contactor, level, load, communication, flow, float out of sequence, phase loss, reversal, and sag or swell
Alarm Notification	Local and SCADA fault display
Security	User-defined password management for access to programming areas in the controller
Diagnostics and Troubleshooting	Time-stamped event logging provides an audit trail of operational data changes and other key data reliability indicators. The SEL-2411P provides waveform analysis of the lift station voltage and phase monitoring. This function requires a SELEcT™ 3 ac voltage input (AVI) card.

SEL SCHWEITZER ENGINEERING LABORATORIES

Making Electric Power Safer, More Reliable, and More Economical
+1.509.332.1890 | info@selinc.com | selinc.com

© 2020 by Schweitzer Engineering Laboratories, Inc.
PF00192 • 20200102

