

SEL-2414

Transformer Monitor



Complete control and monitoring solution to protect critical substation assets

- Track transformer life with IEEE or IEC thermal models and through-fault monitoring.
- Regulate transformer voltage with automated load tap changer (LTC) control.
- Monitor load tap positions and control statuses to ensure stable voltage and LTC integrity.
- Operate transformer cooling stages and fans to minimize thermal wear.
- Integrate with SCADA systems and distributed control systems (DCSs) using communications protocols, such as IEC 61850 Edition 2, DNP3, and Modbus.
- Select from flexible I/O options to fit your application requirements.



Key Features

Transformer Temperature and Through-Fault Monitoring

Track transformer loss of life using the IEEE C57.91-2011 or IEC 60076-7:2018 thermal model for various winding configurations. Through-fault monitoring helps track events that cause mechanical and thermal stress to transformers.

Load Tap Position and Control Monitoring

Monitor as many as 32 tap positions and the raise and lower controls to ensure the output voltage remains stable. If a tap position fails to change or an unexpected tap position occurs, the SEL-2414 asserts an alarm.

Transformer and Fan Control

Control LTCs to regulate output voltage and provide sufficient power throughout a system. Exercise transformer cooling fans to eliminate maintenance surprises during critical load conditions.

Flexible Logic Programming

Easily program the SEL-2414 with powerful logic, math, timer, counter, and edge-trigger functions. Implement logic with SELOGIC[®] control equations or standard logic gates using the ACSELERATOR QuickSet[®] SEL-5030 Software graphical logic editor.

Flexible I/O Configuration

Select I/O options to meet your system requirements. Options include digital or analog outputs; digital, analog, resistance temperature detector (RTD), and ac current inputs; and ac voltage inputs.

Easy Integration With SCADA

Flexible communications options provide easy integration with SCADA systems and DCSs. Choose from Ethernet (Modbus TCP, DNP3 LAN/WAN, IEC 61850 Edition 2, the Parallel Redundancy Protocol, Telnet, FTP, and Simple Network Time Protocol) and serial (Modbus and DNP3 RTU) protocols.

Event Analysis

Conduct postevent analysis more efficiently with detailed event records. The SEL-2414 has a Sequential Events Recorder (SER) that stores up to 512 SER reports of digital input transitions, time-tagged to the nearest millisecond. You can send the SER data to an automation controller or computer for system analysis.

Reliability in Harsh Environments

Designed and manufactured to reliably operate in harsh physical and electrical environments, the SEL-2414 withstands vibration, electrical surges, fast transients, and extreme operating temperatures of -40° to $+85^{\circ}\text{C}$ (-40° to $+185^{\circ}\text{F}$) and meets stringent industry standards. In addition, the SEL-2414 is Underwriters Laboratories (UL) Class I, Division 2-certified for use in hazardous and potentially explosive environments.

Simple Integration and Configuration

Optional Cards

- Serial communications (EIA-232/EIA-485)
- 8 analog inputs (AI)
- 8 digital inputs (DI)
- 14 DI
- 8 digital outputs (DO)—electromechanical (8 Form A; 8 Form B; 6 Form A, 2 Form B; or 2 Form A, 6 Form B)
- 4 DI, 3 DO (2 Form C, 1 Form B)—electromechanical
- 4 DI, 4 DO—electromechanical
- 4 DI, 4 DO—high-speed, fast high-current interrupting
- 4 AI, 4 analog outputs (AO)
- 3 ac voltage inputs
- 4 ac current inputs
- 3 ac current and 3 ac voltage inputs
- 10 RTD inputs
- 10 RTD/TC inputs

Designer Templates

Use QuickSet to create designer templates of your settings and hide all settings that do not need to change for common applications. The SEL-2414 retains a copy of the template in internal memory.

Simple Commissioning

Access complete configuration functions and display settings, measurements, and calculated values on the front panel. The SEL-2414 is also easily set with QuickSet.

Flexible Mounting Options

Mount the SEL-2414 into multiple locations using our complete line of mounting and enclosure options.

No cutting or drilling is required when you use the optional mounting kits.

Visit selinc.com/applications/mountingselector to see the complete selection of mounting and enclosure kits.



Overview

Optional surface-mount chassis is available.

2 × 16 character LCD provides navigation, control, data, and diagnostics via default messages or customizable display messages.

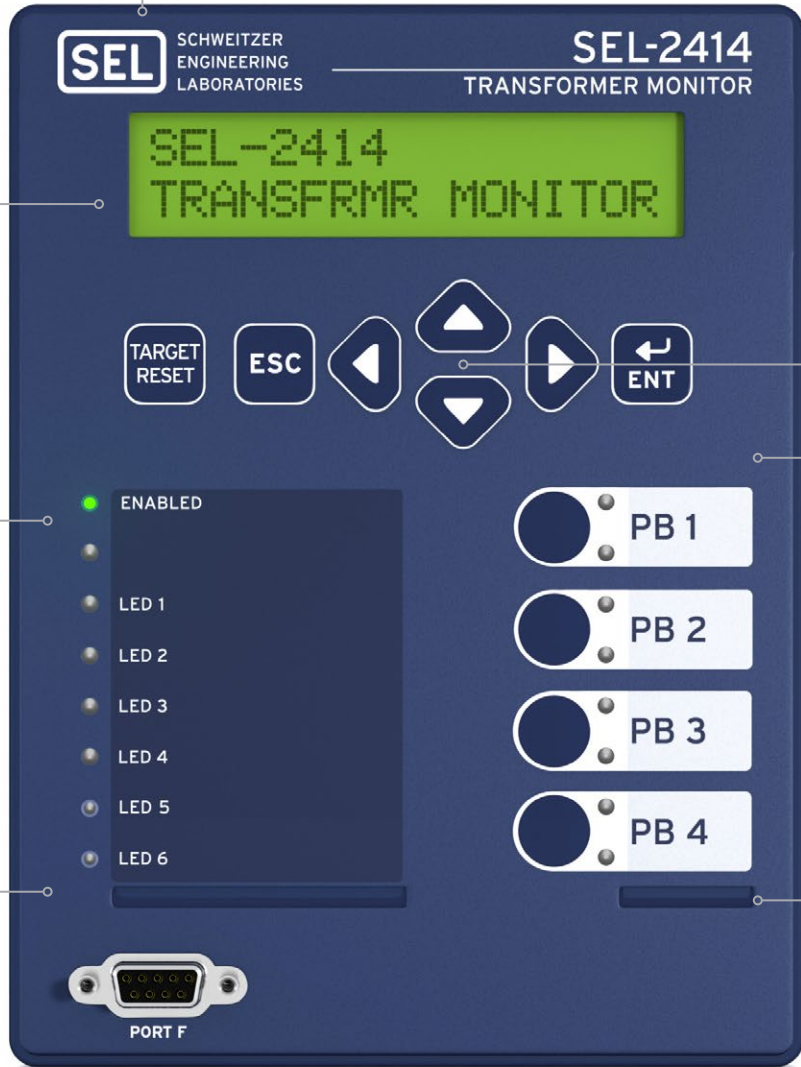

Simple front-panel navigation provides operator access to settings and operational data.

Programmable front-panel LEDs with user-configurable labels alert operators to conditions.

Programmable operator pushbuttons with user-configurable labels allow front-panel customization.

Power supply options include 24/48 Vdc or 110/250 Vdc, 110/230 Vac.

Wide variety of protocols and media options allow communication with other devices and control systems.

Four available slots for SElect™ I/O cards expand application options.

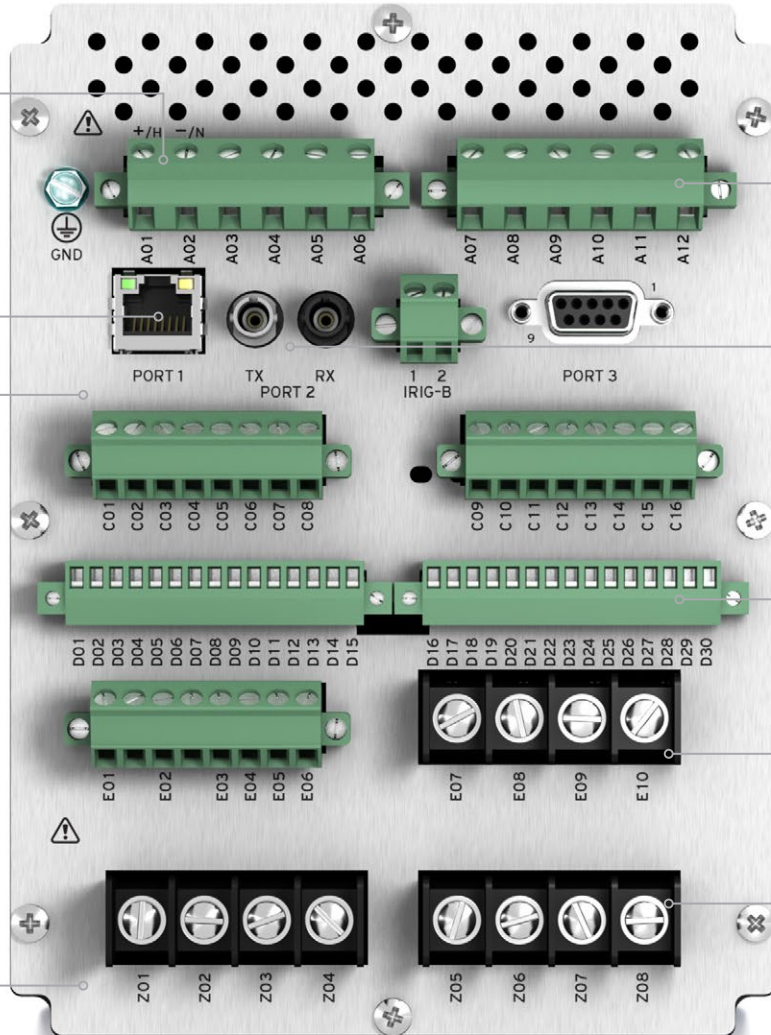

Standard I/O includes three digital outputs and two digital inputs.

Optional fiber-optic serial port provides quick and easy access.

Ten RTD input card option increases I/O.

Three ac current/three ac voltage input option.

Four ac current input option.

Applications

Transformer Temperature and Through-Fault Monitoring

The SEL-2414 includes IEEE C57.91-2011 and IEC 60076-7:2018 thermal models to monitor the thermal condition of oil-filled transformers in various winding configurations, including three sets of single-phase transformers.

Calculate top oil, hotspot, insulation aging acceleration factor, and loss of life while generating hourly and daily data about your transformer. Capture through-fault current data that could lead to increased transformer wear. Assert alarms based on the thermal condition of the transformer or on other monitored conditions.

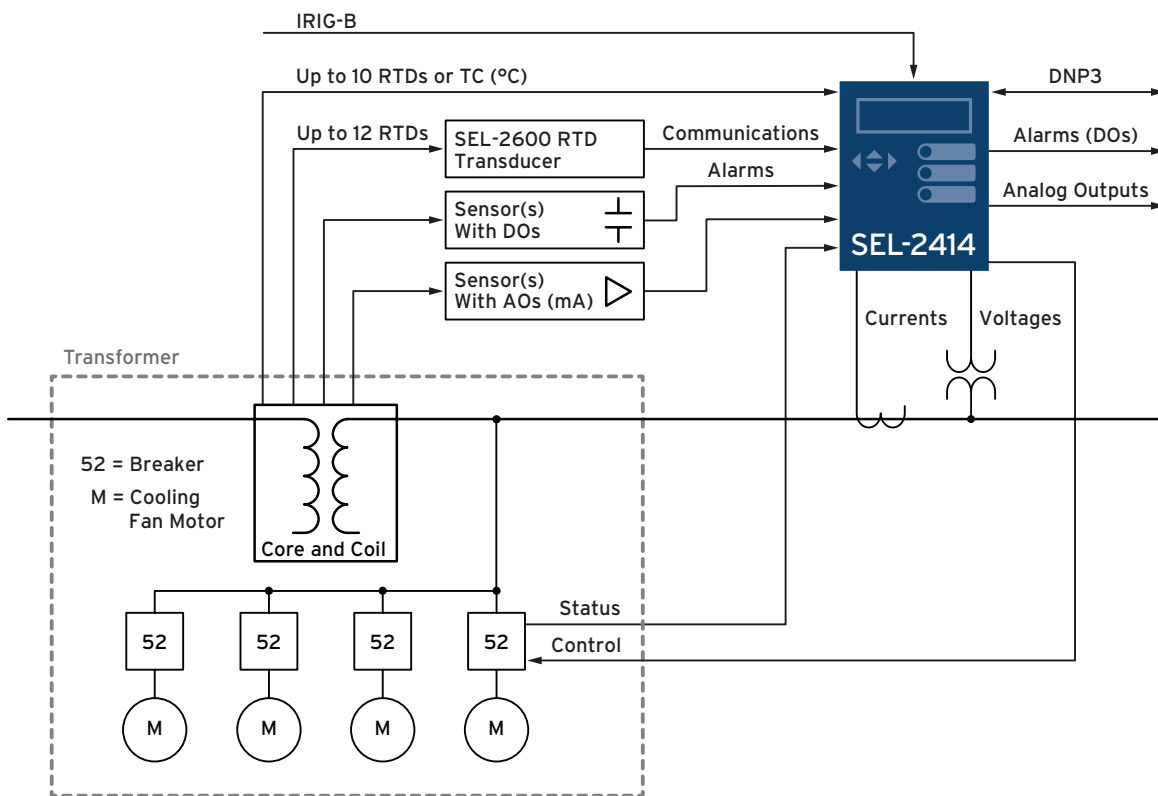

Transformer monitor system example.

Load Tap Position and Control Monitoring

Monitor as many as 32 tap positions (with one or three neutral tap positions) and the raise and lower controls using the optional 14-digital-input card. Individual tap position monitoring occurs via nonvolatile variables, while voltage regulation is implemented with measured voltages, timers, and analog control variables. If a tap position fails to change or an unexpected tap position occurs, the SEL-2414 asserts an alarm.

Transformer and Fan Control

LTC control, which is used in applications ranging from distribution transformers to large autotransformers, helps regulate output voltage to provide sufficient power throughout a system. Controlling transformer cooling fans and fan banks ensures that transformer temperatures remain stable and that cooling cycles are balanced, thereby increasing the life of the system. You can implement LTC and fan control with QuickSet design templates.

Electrical Substation SCADA, Report Retrieval, and Engineering Access

Instead of settling for a remote terminal unit (RTU), use SEL automation controllers, relays, remote I/O modules, and the SEL-2414 for higher reliability, lower cost, and more functions. An RTU provides only remote I/O for SCADA without the benefit of the other functions available in a distributed SEL system. With the SEL-2414, you can:

- Provide digital and analog I/O to SEL automation controllers.
- Implement high-speed automatic control loops with SELogic control equations using combinational logic, analog comparison, edge-trigger, and timer functions.
- Manage protection and control settings, retrieve and file power system reports, time-tag changes to the nearest millisecond, and directly access devices for engineering maintenance.

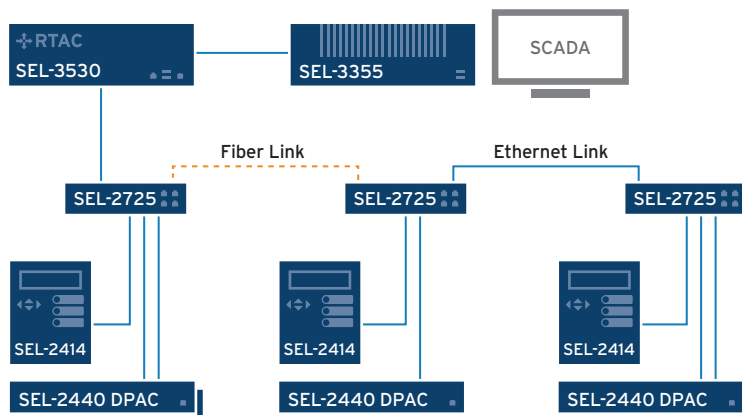

Distributed substation SCADA example.

Specifications

General Specifications

AC Current Inputs	5 A or 1 A
AC Voltage Inputs	300 Vac
Power Supply	110/250 Vdc, 110/230 Vac Input voltage range: 85–275 Vdc, 85–264 Vac 24/48 Vdc Input voltage range: 19.2–60.0 Vdc
Communications	Two EIA-232 ports and a third optional EIA-232/EIA-485 port using one expansion card position. Single or dual Ethernet ports: 10/100BASE-T port 100BASE-FX fiber-optic port Optional fiber-optic serial communications port
Protocols	Standard: Modbus RTU, Modbus TCP, DNP3, DNP3 LAN/WAN, MIRRORING BITS [®] communications, SEL Fast Meter, SEL Fast SER, SEL ASCII and binary communications, and the Parallel Redundancy Protocol (PRP) Optional: DNP3 Level 2 Outstation and IEC 61850 Edition 2
Operating Temperature	IEC performance rating –40° to +85°C (–40° to +185°F) Class 1, Zone 2 rating of –40° to +70°C (–40° to +158°F) Note: LCD contrast is impaired for temperatures below –20°C (–4°F) and above +70°C (+158°F).
Mount	Panel or surface mount
Dimensions	Vertical Panel Mount Height: 192 mm (7.56 in) Width: 144 mm (5.67 in) Depth: 147.4 mm (5.8 in) Vertical Surface Mount Height: 215.9 mm (8.5 in) Width: 165.1 mm (6.5 in) Depth: 190.5 mm (7.5 in)



Making Electric Power Safer, More Reliable, and More Economical
+1.509.332.1890 | info@selinc.com | selinc.com

© 2021 by Schweitzer Engineering Laboratories, Inc.
PF00178 • 20210730

