

SEL-587Z



High-Impedance Differential Relay

Bus or Transformer High-Impedance Differential Relay



Apply the SEL-587Z Relay for single-zone bus protection, reactor protection, or sensitive restricted earth fault protection on grounded, wye-connected power transformer windings.

Features and Benefits

Protection

Use high-impedance differential elements for fast tripping for in-zone faults, while providing security during heavy through faults and CT saturation. Reduce panel design cost and space requirements by using a single relay that includes three-phase protection, resistors, and metal oxide varistors (MOVs).

Control

Use front-panel pushbuttons to save the expense of separately mounted control switches. Serial port communication provides for remote control of circuit breakers or other user-defined functions.

Reporting, Monitoring, and Metering

Simplify fault analysis with event reports and Sequential Events Recorder (SER). Validate CT connections using the metered voltage differential quantities.

Communications

Integrate the relay with SCADA, local HMI, or modems using Modbus®, SEL ASCII, and SEL Fast Messaging protocols through the rear-panel isolated communications port. Use the front-panel communications port for relay settings and event report retrieval.

Making Electric Power Safer, More Reliable, and More Economical®

Functional Overview

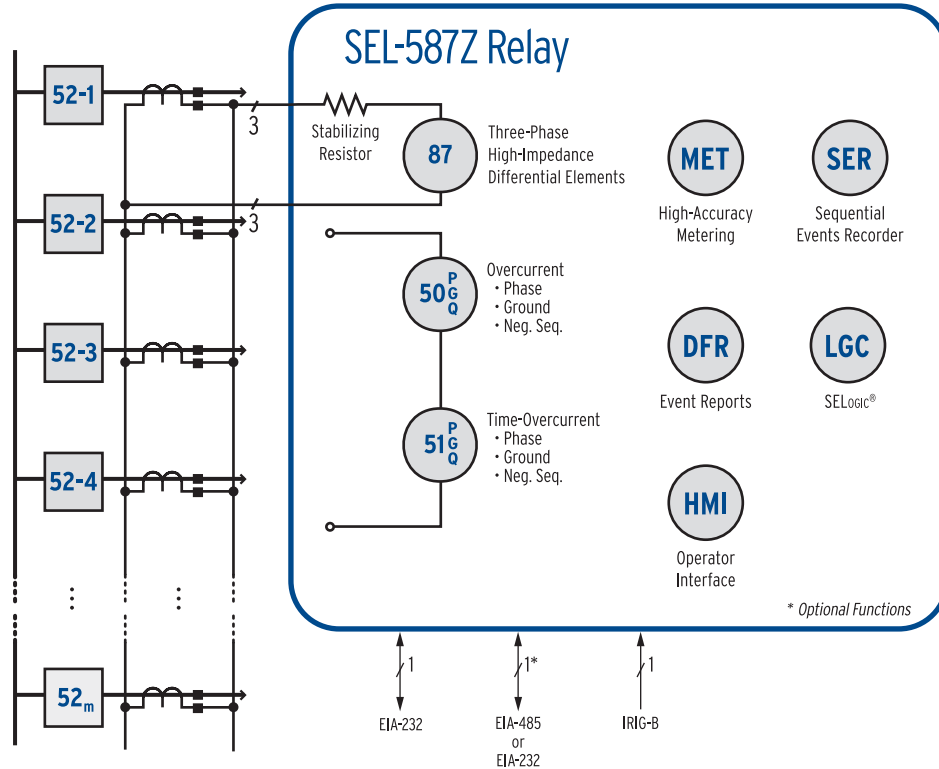

Differential Protection

The SEL-587Z Relay has three independent high-impedance elements, each with two setting levels, with all differential elements set in volts. As shown below, the faulted-circuit CT can saturate during through faults. High-impedance differential protection offers immunity against relay misoperation resulting from CT saturation, provided that the stabilizing resistor is of sufficiently high value. To comply with this requirement, the SEL-587Z Relay uses 2000-ohm resistors, large enough to provide security against CT saturation for through faults.

During bus faults, the voltage across the resistor can rise to unacceptably high values if not limited. MOVs in parallel with each high-impedance element clamp the secondary peak voltage to less than 2 kV.

For best performance, select current transformers with fully distributed windings and identical ratios.

For other SEL-587Z applications that involve mismatched current transformers, contact SEL.

Use the second level of the high-impedance element as a CT open-circuit alarm by configuring the setting with a low value.

Install the SEL-587Z Relay on transformers with grounded-wye windings for sensitive restricted earth fault protection. The combination of restricted earth fault protection and overcurrent elements will protect smaller transformers where differential protection is not economical.

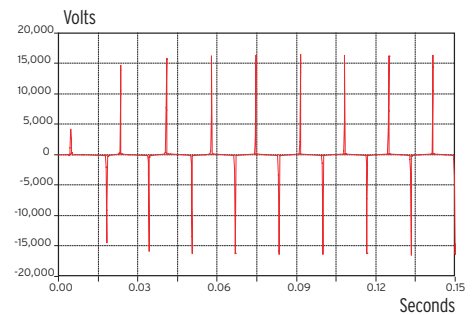

Voltage without MOV.

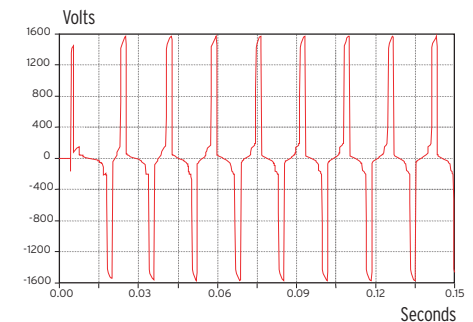

MOV-clamped voltage.

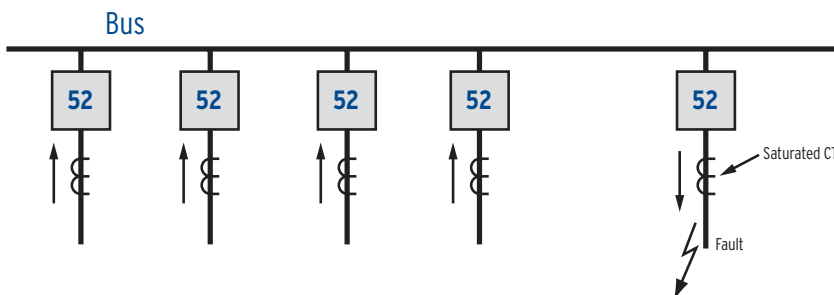

Overcurrent Protection

Overcurrent elements include a maximum-phase measurement, phase-specific elements, and negative-sequence and residual overcurrent elements. Use the independent overcurrent elements for protecting other equipment.

Apply the SEL-587Z overcurrent elements for transformer protection. These elements provide instantaneous overcurrent protection for bushing faults and time-overcurrent protection for coordination with other system protection.

Sequential Events Recorder

Use the time- and date-tagged sequential events messages recorded by the SEL-587Z Relay to analyze the time relationships between assertion and deassertion of logical elements within the relay.

Event Reports

Analyze faults from the event reports, which include 15 cycles of all the analog values measured in the relay as well as most of the digital information. Use ACSELEATOR Analytic Assistant® SEL-5601 Software for a graphical representation of the data.

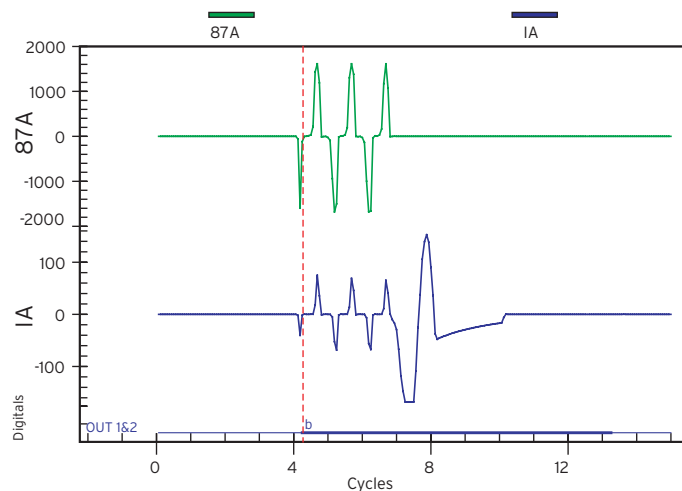

The first trace is a high-impedance voltage—87A with maximum value about 1600 V. The second trace is a low-impedance current—IA, which represents the total current through the resistor and MOV.

Metering Functions

Voltage 87A, 87B, 87C	Voltages from each differential element
Current IA, IB, IC, IG, 3I2	Separate phase, negative-sequence, and residual currents
Demand current IA, IB, IC, IG, 3I2	Separate phase, negative-sequence, and residual currents

SELogic® Control Equations

SELogic control equations put relay logic in the hands of the protection engineer. Assign relay inputs to suit the application. Logically combine selected relay elements for various control functions, and assign outputs to logic functions. Eliminate traditional panel control switches with eight local control switches and RTU-to-relay wiring with eight remote control switches. Replace traditional indicating panel lights with eight programmable displays.

Applications

High-Impedance Bus Protection

Use the high-impedance elements 87A1, 87B1, and 87C1 for instantaneous high-impedance bus protection. Set the second level of the high-impedance elements—87A2, 87B2, and 87C2—to lower values to detect CT open-circuit conditions.

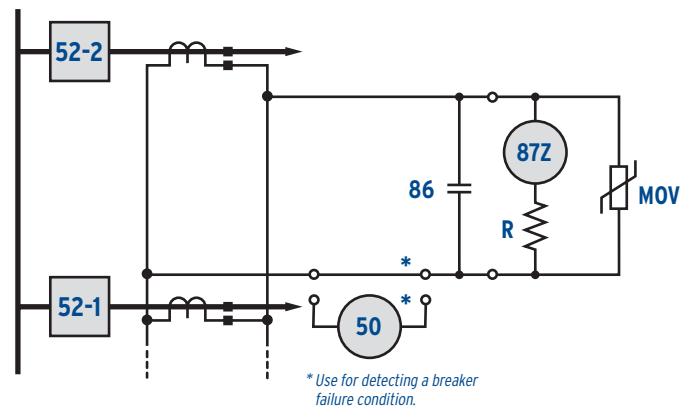

87Z – High-Impedance Differential Element

50 – Overcurrent Element

R – 2000 Ω Stabilizing Resistor

86 – Lockout Relay (not included)

MOV – Metal Oxide Varistor

Breaker Failure/Bus Fault Cleared Detection

Apply the 50/51 overcurrent elements in series with the high-impedance elements to detect breaker failure conditions. Following a bus fault, the lockout relay (86) contacts short out the high-impedance elements, and the entire fault current then flows through the 50/51 elements. Delay operation of the 50 element for a suitable period to give all circuit breakers time to open. An element still picked up after the time delay indicates that one or more circuit breakers have failed to open. Use the 50 elements to send a direct transfer trip command to all adjacent substations to clear the fault, or use these elements to supervise SCADA attempts to re-energize the bus.

SEL-587Z High-Impedance Differential Relay

General Specifications

High-Impedance (87A, 87B, 87C)

150 V continuous, linear to 3000 V symmetrical

Burden 2000 Ω stabilizing resistor

Range 20–800 V

MOV clamping voltage

One or two MOV option 2000 V (8 x 20 μ s)

Four MOV option 1500 V (8 x 20 μ s)

MOV maximum transient energy rating

One MOV—2500 J, two MOV—5000 J, four MOV—8400 J

MOV maximum continuous ac voltage rating

One or two MOV option 750 V

Four MOV option 600 V

AC Current Inputs (IA, IB, IC)

5 A nominal

15 A continuous, 500 A for 1 second, linear to 100 A symmetrical, 625 A for 1 cycle (sinusoidal waveform)

Burden <0.16 VA @ 5 A; <1.15 VA @ 15 A

Range 0.5–80 A

1 A nominal

3 A continuous, 100 A for 1 second, linear to 20 A symmetrical, 250 A for 1 cycle (sinusoidal waveform)

Burden <0.06 VA @ 1 A; <0.18 VA @ 3 A

Range 0.1–16 A

Frequency and Phase Rotation

60/50 Hz system frequency and ABC/ACB rotation

Output Contacts (4 plus 1 alarm)

6 A continuous carry, 30 A make per IEEE C37.90: 1989, 100 A for 1 second, 270 Vac/360 Vdc MOV for differential surge protection, pickup/dropout time: <5 ms

Breaking capacity (L/R = 40 ms, 10,000 operations): 0.75 A @ 24 V; 0.5 A @ 48 V; 0.3 A @ 125 V; 0.2 A @ 250 V

Cyclic capacity (L/R = 40 ms, 2.5 cycles per second): 0.75 A @ 24 V; 0.5 A @ 48 V; 0.3 A @ 125 V; 0.2 A @ 250 V

Optoisolated Input Ratings (2 total)

Any of the following nominal voltages: 24, 48, 125, 250 Vdc

Power Supply Ratings

24 V (polarity sensitive) 16–36 Vdc

48/125 V 36–200 Vdc or 85–140 Vac

125/250 V 85–350 Vdc or 85–264 Vac

5.5 W maximum

Serial Communications

One front-panel EIA-232 serial port, one isolated rear-panel EIA-232 or EIA-485 serial port (specify when ordering), data rate: 300, 1200, 2400, 4800, 9600, 19200, and 38400 bps

Time-Code Input

Demodulated IRIG-B accepted at rear-panel serial port

Operating Temperature

–40° to +85°C (–40° to +185°F)

Mounting Options

Horizontal rack-mount and horizontal panel-mount versions available

Production Dielectric Strength Tests

High-impedance and ac current inputs: 2500 Vac for 10 seconds

Power supply, optoisolated inputs, and output contacts: 3100 Vdc for 10 seconds



Cutaway view showing stabilizing resistors and MOVs.



Pullman, Washington USA
Tel: +1.509.332.1890 • Fax: +1.509.332.7990 • www.selinc.com • info@selinc.com

© 2001–2010 by Schweitzer Engineering Laboratories, Inc. PF00012 • 20101004

