

SEL Overhead and Underground AutoRANGER® Fault Indicators

SEL-AR360, SEL-AR, and SEL-ARU



From selection to installation, simplify your faulted circuit indicator (FCI) management

- Fast, reliable fault locating reduces outage durations on overhead and underground distribution systems.
- Autoconfiguration streamlines installation, simplifies crew training, and reduces selection time.
- Automatic trip threshold adjustment eliminates device replacements to address load fluctuations.
- Versatile devices allow universal application across distribution systems with trip thresholds of 50 to 1,200 A.



Overhead AutoRANGER FCIs

The SEL-AR360 and SEL-AR Overhead AutoRANGER Fault Indicators are self-adjusting fault indicators for overhead lines. You can apply the SEL-AR360 on distribution systems up to 34.5 kV and the SEL-AR on systems up to 69 kV. They automatically select trip thresholds based on the sampled load current and improve system reliability by indicating momentary faults before they become permanent outages.

Momentary and Permanent Fault Identification

Distinct momentary and permanent fault indications help line crews track down and prioritize faults.

Maximum Product and Battery Life

An intelligent LED display provides an appropriate level of intensity for ambient lighting conditions. This battery-saving technology provides more than 2,500 flashing hours for the SEL-AR and more than 1,800 flashing hours for the SEL-AR360.

Reliable Performance

Ramp-Down Restraint® prevents false activation after extended circuit lockout. Inrush restraint prevents false tripping during recloser operations.





SEL

AutoRANGER

AR360

Made in U.S.A.

Underground AutoRANGER FCIs

The SEL-ARU Underground AutoRANGER Fault Indicator is a reliable faulted circuit indicator that automatically selects a minimum trip threshold based on sampled load current. Being able to use one device across many applications simplifies ordering, inventory, and installation.

Dynamic Delayed Trip

A Dynamic Delayed Trip feature improves coordination with upstream protection. It maximizes FCI reliability and increases system reliability on underground distribution circuits, including in pad-mounted transformers or switchgear, subsurface vaults, junction boxes, unfused taps, mid-feeder disconnect switches or sectionalizers, or long feeders.

By monitoring current, the SEL-ARU automatically adjusts its trip response times to better coordinate with upstream protection.

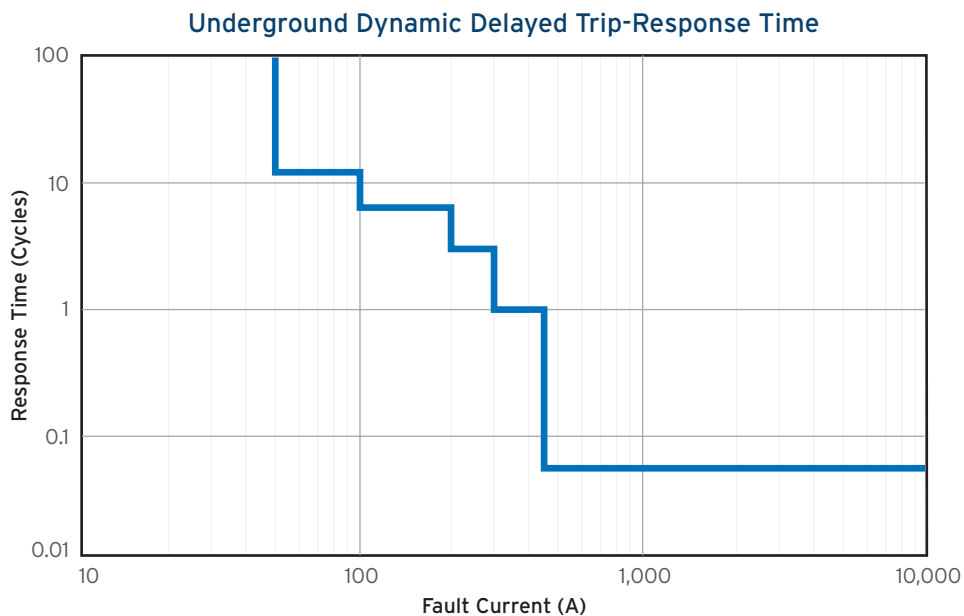

SEL-ARU

Line-Powered Functionality

The energy to power the microprocessor in the SEL-ARU comes from monitored load current rather than a battery, decreasing maintenance and the cost of ownership.

Current-Activated Timed Reset (CATR)

Each SEL-ARU derives a normalization current threshold as a function of measured circuit load. The SEL-ARU uses the normalization current threshold to distinguish circuit restoration from backfeed current. It is this threshold that the SEL-ARU must detect before initiating the reset timer (0, 2, 4, or 8 hours). Upon detecting normalization current, the SEL-ARU indicates a fault for the duration of the reset timer. For example, a 0-hour CATR setting will result in the SEL-ARU automatically resetting upon restoration of load current that meets the normalization current threshold. A 4-hour CATR setting will result in the SEL-ARU automatically resetting 4-hours after circuit restoration. The SEL-ARU interprets currents lower than the normalization current as backfeed and, consequently, delays automatic reset.

Remote Displays That Reduce Fault-Finding Time

Remote displays eliminate the need for line crews to open high-voltage enclosures or enter subsurface vaults during fault-finding patrols. The SEL-ARU is compatible with a variety of remote display options, including nonbattery mechanical flag displays and bright BEACON® LED displays.



Large "L"
Display (BEACON
LED optional)



Standard "V"
Display (BEACON
LED optional)



BEACON Bolt®
display



RadioRANGER®
Remote Fault Reader
(SEL-8310 Display)

Simplify Retrofits With the Remote Fiber-Optic Display

The optional SEL-ARU with a remote fiber-optic display speeds up and simplifies retrofit applications, enabling utilities to upgrade to an FCI solution with a longer operational life than other FCIs on the market. The SEL solution works in pad-mounted distribution equipment with 5/16" fiber-optic display holes. The phase sensor has an integrated LED that will flash until current is restored or the timer expires. The optional fiber-optic cable includes a sealing washer for superior cabinet corrosion protection.



SEL-ARU with integral LED and remote fiber-optic display.



Complete Fault Indication Solution

Working together, SEL FCIs and distribution protection equipment help line crews identify the exact location of a fault. If a fault occurs, an SEL feeder relay calculates the fault location as a distance from the substation to the fault. However, if a feeder has multiple taps (see figure), the relay cannot determine on which tap the fault occurred. SEL FCIs direct the line crews to the faulted section of the line, which can be correlated to the fault location provided by the relay.

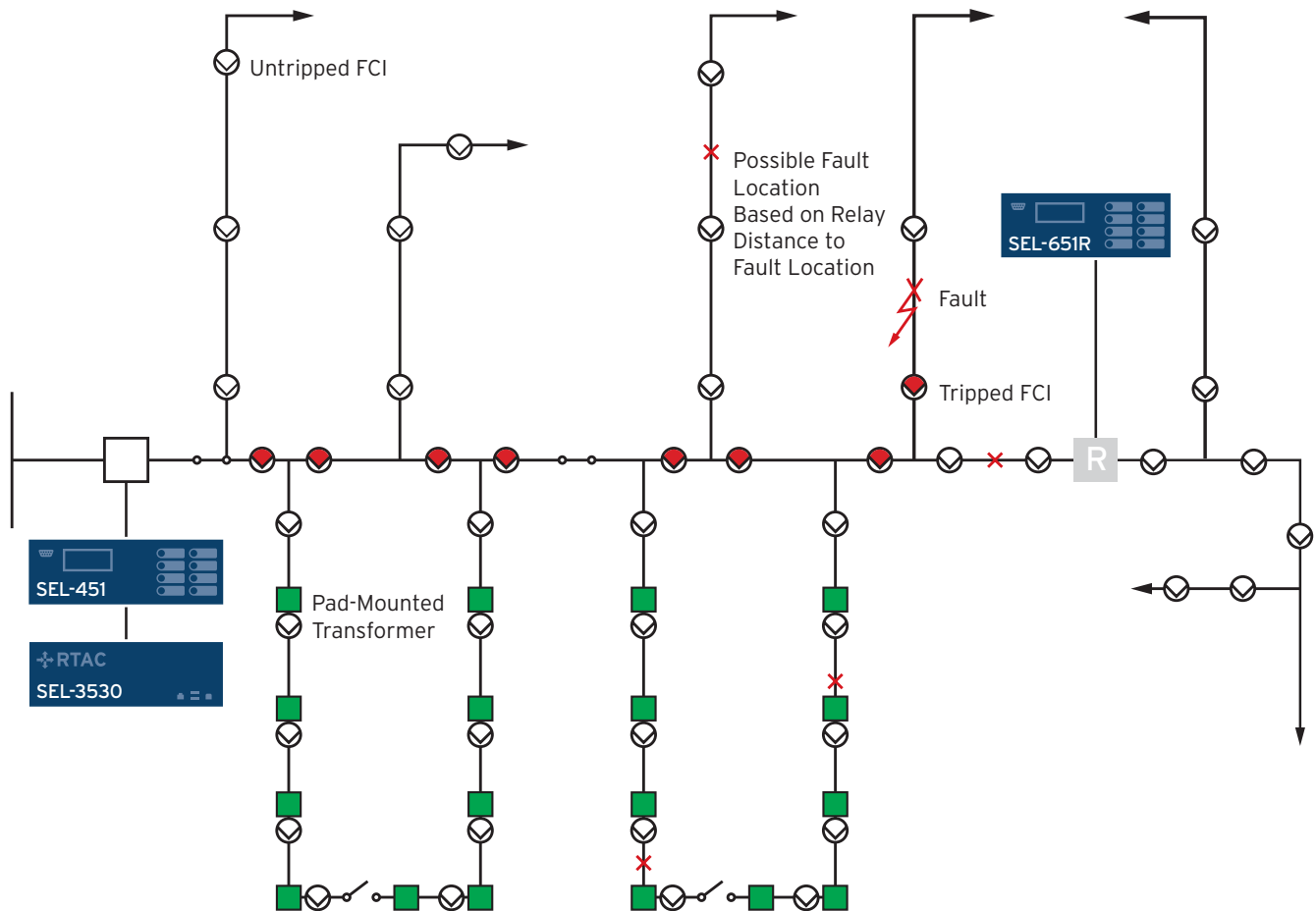

Specifications

Overhead	SEL-AR	SEL-AR360
Trip Threshold Range	50 to 1,200 A	50 to 1,200 A
Voltage Range (phase-to-phase)	4,160 V to 69 kV	4,160 V to 34.5 kV
Maximum Fault Current	25 kA for 10 cycles	25 kA for 10 cycles
Trip Response Time	24 ms, nominal	24 ms, nominal
Permanent Flash-Clearing Times		
50 and 100 A Trip Levels	8 hours	8 hours
200 and 1,200 A Trip Levels	4 or 8 hours	4 or 8 hours
Momentary Flash-Clearing Times		
Momentary Flash-Clearing Times	0 (disabled), 4, 8, 16, or 24 hours	0 (disabled), 4, 8, 16, or 24 hours
Flash Hours	2,500 hours	1,800 hours
Outer Diameter Clamping Range	0.162" to 1.50"	0.162" to 1.50"
Battery	3.6 V high-capacity 8.5 Ah lithium battery with a 20-year life	3.6 V high-capacity 17 Ah lithium battery with a 20-year life
Approximate Weight	600 g (1.30 lbs)	840 g (1.85 lbs)
Temperature Range	-40° to +85°C (-40° to +185°F)	-40° to +85°C (-40° to +185°F)

Underground	SEL-ARU	SEL-ARU With Fiber-Optic Display
Trip Thresholds	50 to 1,200 A	50 to 1,200 A
Voltage Range	Equal to voltage class of shielded underground cable	Equal to voltage class of shielded underground cable
Maximum Fault Current	25 kA for 10 cycles	25 kA for 10 cycles
Minimum Operating Current	3 A continuous	3 A continuous
Current-Activated Timed Reset	0, 2, 4, 8, or 12 hours	N/A
Time Reset With Current Reset Override	N/A	0, 2, 4, or 8 hours
Battery (for BEACON LED display only)	3.6 V high-capacity lithium battery with a 20-year life	3.6 V high-capacity lithium battery with a 20-year life
Trip Response Time	Function of trip threshold	Function of trip threshold
Inrush Restraint Response Time	5 cycles	5 cycles
Approximate Weight	560 g (1.25 lbs)	840 g (1.85 lbs)
Temperature Range	-40° to +85°C (-40° to +185°F)	-40° to +85°C (-40° to +185°F)

SCHWEITZER ENGINEERING LABORATORIES

Making Electric Power Safer, More Reliable, and More Economical
 +1.509.332.1890 | info@selinc.com | selinc.com

© 2019 by Schweitzer Engineering Laboratories, Inc.
 PF00131 • 20190502

