

# Cost Savings of Fiber-Optic Links Instead of Hard-Wired I/O

Gary Scheer

## INTRODUCTION

There are compelling reasons to use fiber-optic data links to transfer digital inputs and outputs (I/O) instead of using discrete copper wire in electrical substations, industrial plants, or other facilities. Because the optical fibers are insulators, they provide no path for electricity to endanger personnel or damage equipment. The data integrity is much better because electromagnetic noise does not interfere with optically transmitted data, and there are no paths for signal ground loops. The system is more reliable, because the links are continuously monitored and the number of connections is much lower [1]. And all of these benefits come with a cost reduction instead of a cost premium!

## EXAMPLE COMPARISON

An example installation has 16 digital inputs (DI) and 16 digital outputs (DO) connected to a marshalling kiosk with 32 one-pair cables. Two approaches are evaluated for connecting the kiosk I/O to a remote control house located 350 cable-feet away:

- Eight cables, each with eight pairs of copper wire
- One fiber-optic cable with four fibers

### Hard-Wired Configuration

The marshalling kiosk includes 64 positions of terminal strips for connecting the field wiring to cables that run between the kiosk and control house. Figure 1 shows a common wiring method. Near the control house entry point, outdoor cables are connected to terminal blocks. Indoor cabling connects to terminals near the panel. Jumper wires connect to the digital I/O terminations on the relays or controllers that use the I/O.

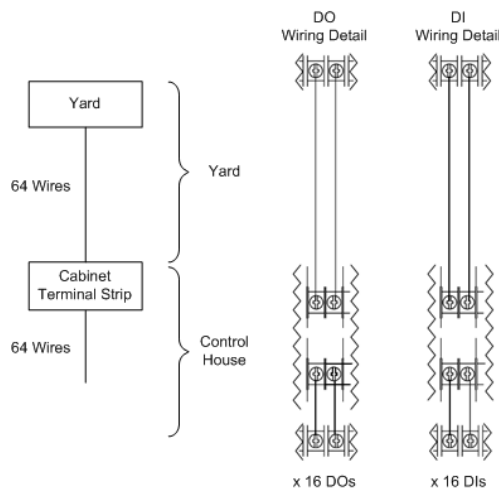
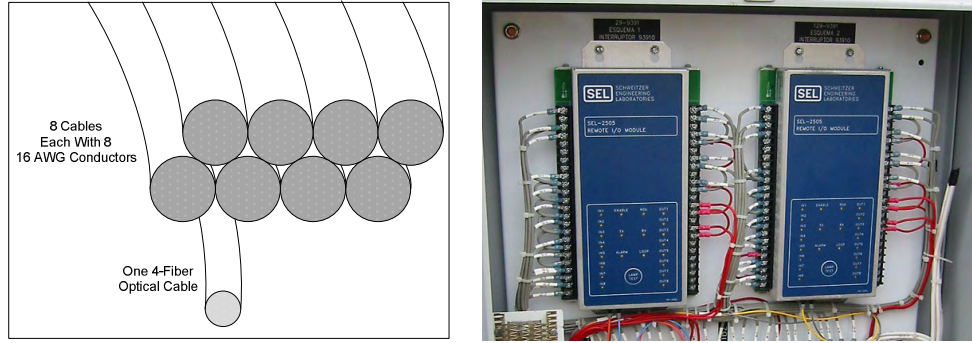

Figure 1 Hard-Wired Diagram

Description	Cost
Terminal strips/lugs	\$ 272
350' x 8 cables x 8 wires	4,858
I/O board	1,000
<b>Total</b>	<b>\$ 6,130</b>



**Figure 2 One 0.3-Inch Diameter Fiber-Optic Cable Instead of Eight 0.57-Inch Copper Cables and I/O Modules in Kiosk for 16 Inputs and 16 Outputs**

**Fiber-Optic Solution**

Two SEL I/O modules are mounted in the marshalling kiosk. For high-speed protection applications, use SEL-2505 Remote I/O Modules; to communicate to an information processor, use SEL-2515 Remote I/O Modules. The field wiring lands on terminal strips on the I/O modules. Each module uses two fibers to communicate to the control house. In the control house, the fibers are connected to SEL-2800 Fiber-Optic Transceivers; each transceiver is connected to an EIA-232 port on a relay or information processor.

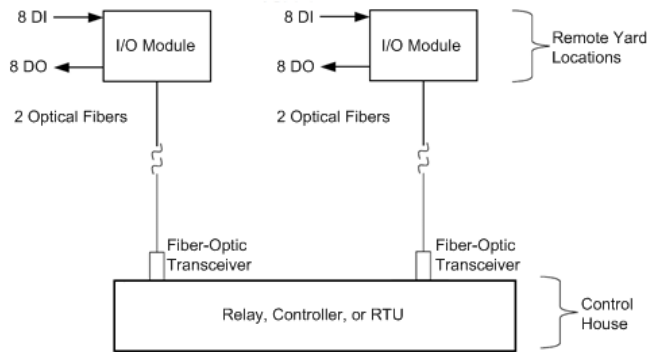

**Figure 3 Fiber-Optic Diagram**

<b>Description</b>	<b>Cost</b>
2 I/O modules	\$ 1,000
350' x 1 cable x 4 fibers	1,053
350' power wiring	235
2 fiber-optic transceivers	218
<b>Total</b>	<b>\$ 2,506</b>

**CONCLUSIONS**

The fiber-optic solution has only 40 percent of the material costs of hard-wired I/O. It involves far less labor to document, install, and test four fibers without intervening terminal strips than 64 wires plus multiple terminal blocks and terminations. The fiber-optic solution uses less than 5 percent of the copper wire of the hard-wired approach: three wires for power and ground, compared to 64 I/O wires. And the fiber-optic I/O solution is more reliable, provides higher data integrity, and protects personnel and equipment.

**REFERENCE**

[1] G. Scheer and R. Moxley, "Digital Communications Improve Contact I/O Reliability," proceedings of the 7th Annual Western Power Delivery Automation Conference, Spokane, WA, May, 2005.