

CASE STUDY

La Venta II Wind Farm—Oaxaca, Mexico

Wind Farm in Mexico Completes First Successful IEC 61850 Application With Multivendor Interoperability

Comisión Federal de Electricidad (CFE) is Mexico's national utility and major provider of electric power. Including independent producer partners, CFE generates 49,893.34 MW of electricity annually from hydro, thermal, geothermal, wind, coal-fired, and nuclear power plants throughout the country. CFE also manages this power and distributes it across 48,635 km of transmission lines.

Besides geothermal power, the only emission-free alternate power source available for development by CFE is wind-driven power, of which the La Venta II wind farm is the most significant project.

La Venta II is located in the southern state of Oaxaca, where the La Ventosa region provides high energy-content winds (the average wind speed is over 9 meters per second). Today, the La Venta II wind farm has a rated capacity of approximately 85 MW. When completed, the project will be the largest wind farm in Mexico and Central America, generating close to 3 GW by 2017.

“Following a successful Phase I pilot program, the second phase called La Venta II was undertaken. Schweitzer Engineering Laboratories (SEL) was involved in the design, manufacturing, testing, and commissioning of the protection panels and integrated system for the substation,” says Julian Alzate, Product Development Manager for SEL. Alzate plays an integral role in the design, implementation, and management of projects involving new SEL technologies.



Figure 1—La Venta II wind farm during construction phase.

“La Venta II boasts 100 wind generators in groups of 20 to be connected to the 34.5 kV bus,” Alzate explains. “In 230 kV, a main/auxiliary bus arrangement will connect the wind farm to the national grid.”

Considering the international scope of this project, CFE decided to build La Venta II's transmission, protection, and control system using the IEC 61850 substation automation standard, which provides methods of developing best engineering practices for substation protection, integration, control, monitoring, metering, and testing. This approach enables CFE to evaluate the technologies selected for possible inclusion into future design standards.

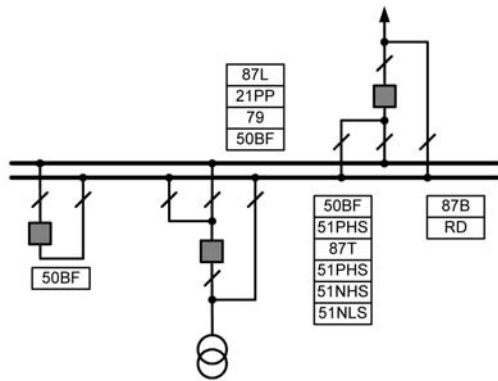

Figure 2—The 230 kV main bus/auxiliary bus array connects the wind farm to the national grid.

“The bid for the substation construction was won by IBERINCO (IBERDROLA Ingeniería y Construcción), a prominent engineering firm,” says Alzate. “IBERINCO was one of a handful of companies with real-life IEC 61850 experience, having built some of the first IEC 61850 substations in Spain.”

The La Venta II project required that the system meet existing CFE substation integrated system requirements using IEC 61850, including:

- Bay control and protection units, with IEC 61850 incorporated directly into the network
- GOOSE messages for interlocks
- Redundant SCADA gateways with DNP3 and Conitel 2020 protocols
- Redundant local HMI

CFE substation protection requirements included:

- Conventional wiring and IEC 61850 GOOSE messaging
- Performance testing of conventional wiring vs. GOOSE for protection functions
- Confirmation that all relays will interoperate and perform as desired
- IEDs with CFE approval

Because IEC 61850 requires interoperability of products from multiple vendors, IBERINCO and CFE invited several prominent manufacturers to participate in the project. For varying reasons, however, the majority of the manufacturers decided not to participate.

“In addition to the primary protection and control equipment, CFE invited all vendors to submit potential IEDs,” says Alzate. “The goal was for them to demonstrate the product’s ability to communicate via IEC 61850.” All IEDs provided for testing purposes were installed in a panel dedicated to the demonstration.

The completed system integrated 24 devices from 9 different product platforms provided by 6 individual vendors. The vendors included SEL, GE, RuggedCom, Siemens, ZIV, and Team Artech.

The participating vendors were assigned areas of responsibility. IBERINCO provided

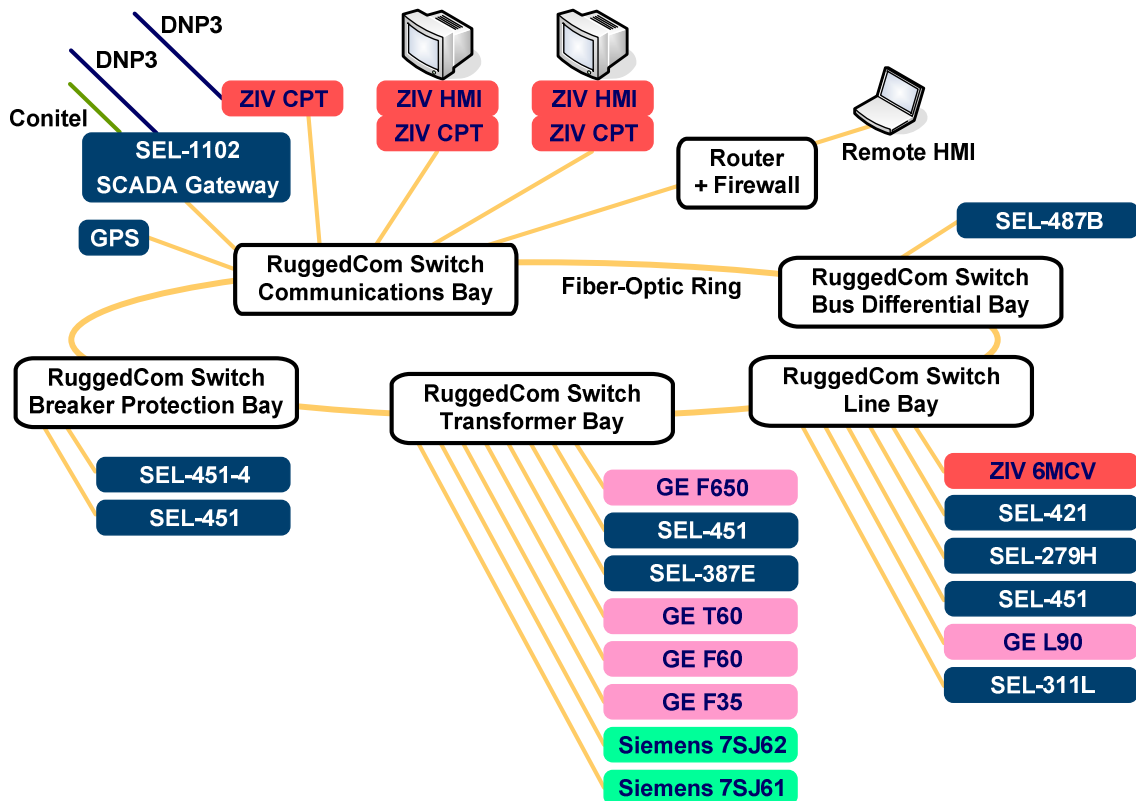

Figure 3—Various connections to the substation fiber-optic Ethernet ring.

the overall project management and the rules for logical devices, logical nodes, controls, and data mapping as well as the HMI and gateway database. ZIV integrated the HMI and provided IEDs for bay control and communications. CFE defined the database to SCADA master and provided the appropriate technical support. SEL provided the protection and control IEDs, built the panels, staged the system, trained the CFE staff, and provided on-site support for commissioning the substation. The other vendors also provided equipment and support as needed.

The La Venta II substation design specified that the devices will directly connect to the Ethernet LAN and allowed no data concentration for data exchange among the IEDs, local HMIs, and protocol gateways. Vendors submitted product designs that performed direct transmission and receipt of IEC 61850 protocols. Data concentration was initially allowed only for the SCADA gateway function that converted IEC 61850 protocols into DNP3 and Conitel 2020. In the end, the

HMIs were served via a data concentrator and did not communicate via the IEC 61850 protocols.

All protection devices were required to be in the LAPEM 5L (list of approved IEDs for use in the CFE network), and all protection schemes were required to meet CFE protection specifications for substation protection functions. Each switch is associated with a specific bay scheme, as shown in Figure 3.

“In addition to using the new IEC 61850 standard, the substation’s integrated communications system incorporated some products that CFE had not used before,” Alzate says. “All of the protective relays had to be independently approved for use by CFE on their system, regardless of their support of IEC 61850 protocols.”

The final design relied heavily on several SEL relays, previously approved by CFE, that now also support IEC 61850.

The IEC 61850 standard requires time stamp resolution to the microsecond. Therefore, the recommended best practice for time synchronization remains IRIG-B because it is the only method that provides this accuracy. SNTP (simple network time protocol) can be used, but it will not provide the accuracy required for some applications.

Future changes to the IEC 61850 standard may recommend a method over Ethernet once one is available. The IEEE is working on IEEE 1588, Standard for Synchronizing Clocks, which may provide microsecond time-synchronization accuracy over Ethernet. However, until then, some vendors suggest that customers use SNTP, which is convenient because it travels over Ethernet and does not require a second connection like IRIG-B.

The accuracy of SNTP is at best within several milliseconds and varies as the network traffic varies. Alzate says that CFE agreed to implement time synchronization via SNTP or IRIG-B to accommodate the different implementations among all the vendors.

CFE requested vendors to provide useful descriptive naming of the IEC 61850 data and groups, such as logical node names, and avoid generic names. Although many vendors used generic names because they conform to the standard, they are not very useful to the end user because the context of the data is lost.

By using generic naming, the vendors eliminate the ability to perform automatic configuration and require the integrator to refer to documentation to interpret generic IEC 61850 values for phase voltage or breaker position.

CFE had planned to continue using the naming convention developed within their organization, whereby all of the databases that receive substation data—protocol gateway, engineering, SCADA, HMI, and

documentation—use the name of the source IED. This CFE naming convention requires 12 characters. Yet some vendors do not support 12 characters in their physical IED description within their IEC 61850 configuration. Although not defined by the standard, end users expect to have enough characters to uniquely name each IED based on their established internal naming conventions. This problematic “local issue” needed to be resolved within the implementation of the IED. Because character length is a local issue, out of the standard’s scope, IEDs were included that did not support CFE’s naming convention. Discovering this issue so late in the project resulted in a significant amount of rework and testing because each element in each database that referred to data from these IEDs had to be changed to the shorter name and then retested.

Overall, the factory acceptance tests took six weeks. SEL, IBERINCO, and ZIV were involved the entire time. Siemens and GE participated in the configuration and testing of their devices.

The process started with the initial network setup, switch configuration, and initial communications tests. This part of the process went quickly but also surfaced some issues.

Some vendors were not able to meet some of the IEC 61850 requirements for the project, and certain adjustments had to be made. For example, as mentioned earlier, physical device names were limited to 8 characters in some IEDs, although the physical name required 12 characters for the project. This required IBERINCO to redefine the database naming conventions, which meant database reconfiguration for all the clients. Most of the limitations found were due to IED limitations and were not resolvable within some of the IEDs. The design team changed databases and naming conventions to accommodate those devices with limitations.

After these problems were addressed, HMIs and SCADA gateways were reconfigured in order to start functional testing. During this second part of testing, new issues were discovered, including:

- The report control block names were not configurable for some of the IEDs.
- Double-point indication for breakers and sectionalizers caused problems when mapped to DNP3 and Conitel 2020.
- IEDs did not support the origin attribute report to the HMI via OrCat (origin category) to discriminate from which level the control was executed and to log the control origin.

“Confirming the successful use of GOOSE messages for protection was the last part of the acceptance testing,” Alzate says. “CFE wanted to perform detailed testing to gain confidence in the new technology. The complete breaker failure protection scheme was implemented using both traditional wiring and GOOSE.”

After status, measurements, and controls were tested, GOOSE messages for interlocks were tested. “With this configuration, it was confirmed that GOOSE was 12 milliseconds faster than hardwire operation,” says Alzate. “That was one of the great accomplishments of the project.”

The La Venta II substation project gave CFE the technical and practical knowledge to

document its unique needs within IEC 61850 and to understand the requirements for interoperability and interchangeability.

###

About CFE/La Venta

CFE is a government-owned utility that generates, transmits, and distributes energy to over 80 million people in Mexico. With 174 generation plants (46,672 MW), over 45,000 km of transmission lines, 135,238 MVAs of transformation, and 8 to 9 percent annual growth, CFE is one of the electric giants of Latin America. La Venta II is located in La Venta, Oaxaca, which is approximately 30 km northwest of Juchitan, Oaxaca. It is the first wind-driven power plant integrated with the Mexico and Latin America web and has a rated capacity of 84.875 MW. For more information, refer to the CFE website at www.cfe.gob.mx.

About SEL

SEL has been making electric power safer, more reliable, and more economical since 1984. This ISO 9001:2000-certified company serves the electric power industry worldwide through the design, manufacture, supply, and support of products and services for power system protection, control, and monitoring. For more information, visit www.selinc.com, or contact SEL by phone: +1 (509) 332-1890; fax: +1 (509) 332-7990; or mail: 2350 NE Hopkins Court, Pullman, WA 99163, USA.

© 2008 by Schweitzer Engineering Laboratories, Inc. All rights reserved.

All brand or product names appearing in this document are the trademark or registered trademark of their respective holders. No SEL trademarks may be used without written permission.

SEL products appearing in this document may be covered by US and Foreign patents. Date Code 20081107

SCHWEITZER ENGINEERING LABORATORIES, INC.

2350 NE Hopkins Court • Pullman, WA 99163-5603 USA
Tel: +1.509.332.1890 • Fax: +1.509.332.7990
www.selinc.com • info@selinc.com

