

# Protection of High-Voltage AC Cables

Demetrios A. Tziouvaras  
*Schweitzer Engineering Laboratories, Inc.*

Revised edition released April 2016

Previously presented at the  
60th Annual Georgia Tech Protective Relaying Conference, May 2006,  
59th Annual Conference for Protective Relay Engineers, April 2006,  
and 5th Annual Clemson University Power Systems Conference, March 2006

Previous revised edition released June 2010

Originally presented at the  
32nd Annual Western Protective Relay Conference, October 2005

# Protection of High-Voltage AC Cables

Demetrios A. Tziouvaras, *Schweitzer Engineering Laboratories, Inc.*

**Abstract**—High-voltage underground ac cables have significantly different electrical characteristics than overhead transmission lines. The cable sheath or shield grounding method has a major impact on the zero-sequence impedance of underground cables. Understanding how the underground cable grounding method affects the series sequence impedances is very fundamental to underground cable protection. In this paper, we briefly discuss the types of underground cables, their bonding and grounding methods, and the fundamental differences between overhead transmission lines and cable electrical characteristics. Finally, we discuss the application of short-circuit protection for high-voltage ac cables.

## I. INTRODUCTION

Underground cables must be protected against excessive overheating caused by fault currents flowing in the cable conductor. High fault currents lasting for a long time generate excessive heating because of  $I^2R$  losses. Excessive heating could damage the cable insulation and the cable itself, requiring lengthy and costly repairs. The cost of high-voltage cable installation is approximately 10 to 15 times that of an overhead transmission line. The time required to locate and repair a fault in an underground cable is 3 to 5 times longer than the time required for an overhead line. Faults in pipe-type cables may burn partially into the steel pipe even if high-speed relaying systems are applied. If the fault is not cleared quickly enough, the arc resulting from an internal pipe-type cable fault tends to burn through the steel pipe. In addition, the radially directed forces on the pipe during prolonged faults can cause weld seam ruptures. These ruptures could have additional environmental implications because thousands of gallons of insulating oil fluid could leak into the ground. This situation could also require longer repair times, especially if water enters the steel pipe.

For these reasons, cable protection must be high speed and typically requires some form of a communications channel between the two ends of the cable circuit. Because most cable faults involve ground initially, ground fault sensitivity is of utmost importance. The protection principles applied to underground cables are similar to the ones applied in extra-high-voltage (EHV) overhead transmission circuits. However, the differences in the electrical characteristics of underground cables and their method of grounding present challenges to protective relaying, especially to ground distance relay elements. Applications of ground distance relays on underground cables can be very challenging because the effective zero-sequence impedance of the cable depends on the return paths of the fault current. These paths vary over a wide range, depending on fault location, bonding and grounding methods of the sheath or shields, the resistivity of

the cable trench backfilling, and the presence of parallel cable circuits, gas pipes, and water pipes.

The electrical characteristics of high-voltage underground ac transmission cables are significantly different from those of overhead transmission lines. Understanding how the cable grounding method affects the series sequence impedances of the cable is very fundamental to underground cable protection. The calculation of the series sequence impedance of cable circuits must include consideration of the magnetic coupling among the phase currents and, in some cases, among currents in the cable sheaths.

In this paper, we discuss how underground cable electrical characteristics and grounding methods impact different protection principles. We also discuss the protection complexities of parallel cable circuits and mixed overhead and cable transmission circuits and provide recommendations for the proper protection of underground cable circuits.

## II. CABLE TYPES

The three types of cables applied in high voltage (HV) and EHV installations are briefly described in the following sections.

### A. High-Pressure Fluid-Filled (HPFF) Pipe-Type

HPFF pipe-type cables have been the most predominantly used type of transmission cable in the United States for several reasons:

- The pipe is very rugged.
- The system is highly reliable.
- The long-term maintenance requirements are lower than earlier self-contained fluid-filled (SCFF) cables.

HPFF cables in the 200 to 275 kV range have been in operation in the United States since the late 1950s; in 1991, the first 345 kV HPFF cable went into operation. HPFF cables have been installed in Japan in the 500 kV network [1].

These cables use a paper tape insulation protected by a spiral shield wire insulated with a hydrocarbon insulating fluid. All three phases are housed inside a steel pipe of adequate size. The coated steel pipes are installed at the site first and tested. Then cables are pulled inside the pipe system, usually with all three phases in trefoil formation. Cathodic protection protects the pipes against corrosion. Adding a return fluid pipe (with an oil circulation and cooling system) in parallel to the conductor pipes allows higher operating capability by recirculation, or forced cooling, of the fluid in the pipe. These systems are provided at the terminals or intermittently along the routes.

In the late 1980s, an alternative to paper insulation, polypropylene paper laminate (PPL), was introduced. PPL is a

laminate comprised of a thin layer of polypropylene tape sandwiched between two layers of paper tape and can be applied using existing manufacturing methods. The advantage of PPL insulation is that it can operate at higher temperatures than the traditional paper-insulated cable and carry a higher current. Since the mid-1980s, EHV HPFF cables have been considered highly reliable, following 20 to 30 years of refining manufacturing and installation methods.

The fluid in the HPFF cable system is an integral part of the cable electrical insulation. The system must be maintained under pressure, approximately 250 psi, to ensure that the oil impregnates the paper insulation. One of the concerns about the use of HPFF cables is the release of the insulating fluid to the environment. Most of the time, this is caused by a breach of the pipe from a third party digging or because a slow-clearing cable fault has burned through the pipe or caused a pipe seam rupture. Because the cable is under pressure, a significant amount of fluid can be released before the leak can be isolated.

### B. Self-Contained Fluid Filled

SCFF cables were the first transmission cables used in the United States. The self-contained cable is internally pressurized with a dielectric fluid, so it is called self-contained fluid-filled cable. Early cables were pressurized to 5 to 15 psi, while newer designs with aluminum or lead reinforced sheaths are pressurized to 75 psi.

The self-contained cable system consists of three individual phases, each contained within a hermetically sealed metallic sheath that is typically extruded lead or aluminum. The cables are insulated with a high-quality taped insulation. The fluid pressure required to suppress ionization is maintained through a hollow core in the center of the conductor.

The seamless metallic sheath prevents moisture entry, contains cable pressure, carries fault currents, and provides mechanical protection.

### C. Solid Dielectric Cross-Linked Polyethylene (XLPE)

Extruded dielectric cables, also known as solid dielectric cables, use cross-linked polyethylene insulation, as shown in Fig. 1.

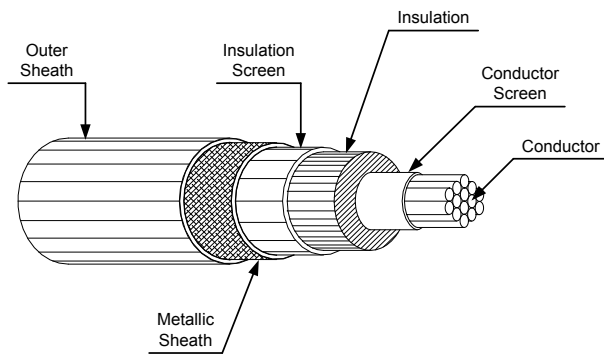

Fig. 1 XLPE cable construction

XLPE is a solid dielectric that was first introduced commercially in the early 1960s. Developments in extrusion techniques, including improvements in premolded accessories,

cleanliness of materials, and reduced costs, have led to an increased application of XLPE cables in HV and EHV networks up to the 500 kV voltage level.

XLPE cables have several advantages over HPFF cables, such as:

- Lower capacitance, resulting in lower steady-state charging current.
- Higher load-carrying capability.
- Lower losses.
- Absence of insulating fluids.
- Lower maintenance costs because there is no dielectric fluid.

XLPE insulated cables may also have advantages in system restoration, especially if pressure loss occurs in an HPFF system after a major disturbance. An HPFF cable may require several days to repressurize and soak the cable to make sure any evolved gas has dissolved back into the dielectric fluid. An XLPE cable, however, can be re-energized immediately.

## III. CABLE SHEATH GROUNDING METHODS

All ac-carrying conductors create an external magnetic field, which induces a voltage to all other nearby conductors that are linked by its field. For safety reasons, cable sheaths or shields must be grounded in at least one point along the cable circuit. Sheath losses in single-conductor cables depend on a number of factors, one of which is the sheath bonding arrangement. Therefore, cable sheath bonding and grounding are necessary to perform the following functions:

- Limit sheath voltages as required by sheath sectionalizing joints.
- Reduce sheath losses to a minimum.
- Maintain a continuous sheath circuit for fault current return and adequate lightning and switching surge protection.

The most common sheath bonding methods are single-point bonding, solid bonding, and cross bonding [2]. They are briefly described in the following sections.

### A. Single-Point Bonding

Single-point bonding is the simplest form of sheath bonding, where the sheaths of the three cables are connected together and grounded at one point along the cable length. This point is typically at one of the two terminals or at the middle of the cables.

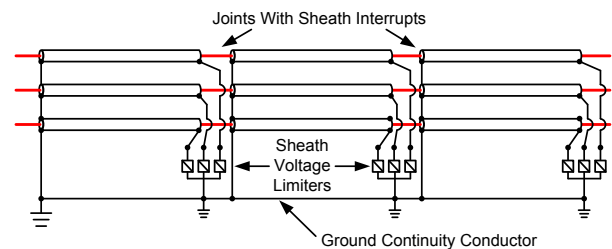

Fig. 2 Single-point bonding

Because there is no closed sheath circuit, current does not flow longitudinally along the sheaths, so no sheath circulating

current loss occurs. In a single-point bonded system, the considerable heating effect of circulating currents in the sheaths is avoided; however, voltages are induced along the length of cable. Particular care must be taken to insulate and provide surge protection at the free end of the sheaths to avoid danger from the induced voltages.

During a ground fault on the power system, the zero-sequence current carried by the cable conductors could return by whatever external paths are available. A ground fault in the immediate vicinity of the cable can cause a large difference in ground potential rise between the two ends of the cable system, posing hazards to personnel and equipment. For this reason, single-point bonded cable installations need a parallel ground conductor, grounded at both ends of the cable route and installed very close to the cable conductors, to carry the fault current during ground faults and to limit the voltage rise of the sheath during ground faults to an acceptable level. The parallel ground continuity conductor is usually insulated to avoid corrosion and transposed, if the cables are not transposed, to avoid circulating currents and losses during normal operating conditions.

### B. Solid Bonding

One way to eliminate the induced voltages is to bond the sheath at both ends of the cable circuit. This eliminates the need for the parallel continuity conductor used in single-point bonding systems. It also eliminates the need to provide surge protection, such as that used at the free end of single-point bonding cable circuits.

The disadvantage of this bonding method is that the considerable heat caused by the circulating currents in the cable sheaths reduces the carrying capacity of the cable circuit.

### C. Cross Bonding

Cross bonding single-conductor cables attempts to neutralize the total induced voltage in the cable sheaths to minimize the circulating current and losses in the cable sheaths, while permitting increased cable spacing and longer runs of cable lengths. Increasing cable spacing increases the thermal independence of each cable, thereby increasing its current-carrying capacity.

The most basic form of cross bonding consists of sectionalizing the cable into three minor sections of equal length and cross connecting the sheaths at each minor section. Three minor cable sections form a major section. The sheaths are then bonded and grounded at the beginning and end of each major section. It is not possible to achieve a complete balance of induced voltages in the cable sheaths if the cables are not either transposed or laid in trefoil configuration. For this reason, cables laid in a flat configuration are transposed at each minor section. This neutralizes the induced sheath voltages, assuming the three minor sections are identical.

Longer cable circuits may consist of a number of major sections in series. When the number of minor sections is

divisible by three, the cable circuit can be arranged to consist of more than one major section. In such a case, the cable circuit could consist of either sectionalized cross bonding or continuous cross bonding. In the case of sectionalized cross bonding, the cables are transposed at each minor section, and the sheaths are bonded together and grounded at the junction of two major sections and at the beginning and end of the cable circuit. In the case of continuous cross bonding, the cables are preferably transposed at each minor section and the sheaths are cross bonded at the end of each minor section throughout the whole cable route. The three cable sheaths are bonded and grounded at the two ends of the route only.

There are many variations of cross bonding for longer cable circuits. Reference [2] provides more details.

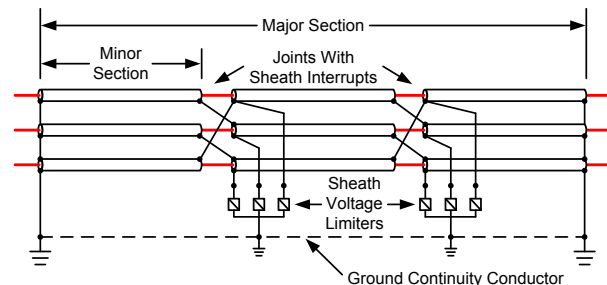

Fig. 3 Cross bonding

## IV. ELECTRICAL CHARACTERISTICS OF CABLE

Electrical characteristics of underground cables differ significantly from overhead transmission lines. Underground cables exhibit a much lower series inductance and a much higher shunt capacitance.

The series inductance of cable circuits is typically 30 to 50 percent lower than overhead lines because of close spacing of cable conductors. The difference in the cable shunt capacitance is even more pronounced and can be 30 to 40 times higher than that of overhead lines. The closer proximity of the cable conductor to ground potential, surrounded by the cable grounded sheath, and the dielectric constant of the insulation, which is several times that of air, cause this difference.

Calculating series sequence impedances for underground cables is not as simple as calculating the series sequence impedance of overhead lines. In underground cables, there is magnetic coupling among the phase currents and, in some cases, among currents in the cable sheaths, depending on the type of sheath bonding. Calculating the series sequence impedances, in general, requires that a set of simultaneous equations be solved for the voltage drop in each of the current-carrying conductors, including the sheaths. Fortunately, calculating the series sequence impedances of single-conductor cables, excluding pipe-type cables, is much easier using approximate formulas [3].

Table I lists the series sequence impedances in  $\Omega/\text{km}$  and the charging current in  $\text{A}/\text{km}$  for two 230 kV cables and an overhead transmission line.

TABLE I  
TYPICAL SERIES IMPEDANCE AND CHARGING CURRENT DATA

Circuit Type	Z1 and Z2 in $\Omega/\text{km}$	Z0 in $\Omega/\text{km}$	Charging Current in A/km
230 kV solid conductor (SC) cable	$0.039 + j 0.127$	$0.172 + j 0.084$	9.37
230 kV high-pressure oil-filled (HPOF) pipe-type cable	$0.034 + j 0.152$	$0.449 + j 0.398$ at 5,000 A	18.00
230 kV overhead line (OH)	$0.060 + j 0.472$	$0.230 + j 1.590$	0.47

The zero-sequence series impedance varies significantly with the resistance of the sheath, the soil electrical resistivity,  $\rho$ , and the presence of any other conductors, water pipes, and adjacent cables. Underground cables have sheaths or shields that are grounded in one or in several locations along the cable length. During unbalanced faults, the ground current can return through the sheath only, through the ground only, through the sheath and the ground in parallel, or through the ground and sheath of adjacent cables.

The presence of water pipes, gas pipes, railways, and other parallel cables makes the zero-sequence current return path rather complex. All of the above factors make the zero-sequence impedance calculations often difficult to determine precisely and, in many cases, questionable, even with the use of modern computers. Therefore, many utilities perform field tests during cable commissioning to measure the zero-sequence impedance value of single-conductor cables.

Table II lists the zero-sequence impedances of a 1,000 m, 230 kV, single-conductor 1,200 mm<sup>2</sup> copper cable. The cable dimensions, laying arrangement, and derivation of the cable parameters are shown in the appendix.

TABLE II  
ZERO-SEQUENCE IMPEDANCES FOR AN SC CABLE  
WITH THREE DIFFERENT GROUND RETURN PATHS

Ground Return Current Path	Z0 in $\Omega$
Sheath only	$0.174 + j 0.073$
Ground only	$0.195 + j 2.166$
Ground and sheath in parallel	$0.172 + j 0.084$

Pipe-type cables are the most common type of transmission cables installed in the United States. Unfortunately, the impedance calculation methods for pipe-type cables are the least refined. The nonlinear permeability and losses in the steel pipe make it very difficult to calculate the flux linkage within the wall of the pipe and external to the pipe.

Electromagnetic effects in the steel pipe make determining zero-sequence impedance for pipe-type cables more complex than for single-conductor cables. This compounds the normal issues of ground-current return paths mentioned previously. The most common method for calculating the sequence impedances of a pipe-type cable is based on an analysis of pipe-type cable impedances performed by Neher in 1964 [4].

Neher derived empirical formulas based on laboratory test measurements on short sections of pipe-type cables. Neher's formulas are of questionable accuracy, especially for the zero-sequence impedance, but there are no other methods currently available that provide more accurate results. Reference [5] presents an improved method for calculating the zero-sequence impedance of pipe-type cables using a finite element solution technique, but this method has not been used extensively yet by the industry.

Another problem with calculating the zero-sequence impedance of pipe-type cables is that the zero-sequence impedance varies with the effective permeability of the steel pipe, and the permeability of the steel pipe varies with the magnitude of the zero-sequence current. Under unbalanced fault conditions, a pipe made of magnetic material, such as steel, can be driven into saturation. Because the pipe forms part of the return path for ground currents, changes in its effective resistance and reactance alter the cable zero-sequence impedance. The nonlinear magnetic characteristics of the steel pipe cause the equations that relate the series voltage drop along the pipe-type cable to the current flowing in each of the conductors to become nonlinear simultaneous equations.

Most utilities obtain the sequence impedances for pipe-type cables from cable manufacturers, including the variation of the zero-sequence impedance as a function of ground current magnitude. Fig. 4 illustrates the variation of the zero-sequence impedance with ground fault current for a 230 kV, 3,500 kcmil HPOF pipe-type cable in a 10.75-inch pipe.

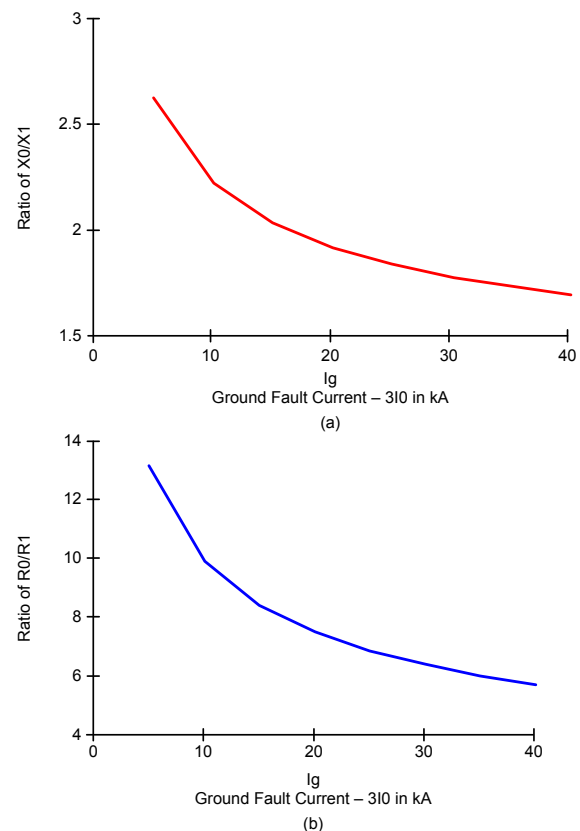

Fig. 4 Variation of zero-sequence resistance and reactance in a 230 kV pipe-type cable as a function of ground fault current

The variation of the zero-sequence impedance shown in Fig. 4 is for currents greater than 5 kA and is applicable for fault current calculations. The nonlinearity of the zero-sequence impedance for currents below 5 kA is more pronounced. Reference [6] provides more detailed data about the variation of zero-sequence impedance of pipe-type cables for ground currents below 5 kA.

Short-circuit programs cannot handle nonlinearities, such as the variation that steel pipe saturation causes in zero-sequence impedance of pipe-type cables. For that reason, short-circuit studies near pipe-type cables will probably require an iterative process for better accuracy [6]. Using a linear short-circuit model and a few discrete zero-sequence impedance data for different levels of pipe saturation (i.e., low [unsaturated], medium, and high currents [saturated]) with a couple of iterations will be adequate.

## V. SHORT-CIRCUIT PROTECTION OF UNDERGROUND CABLES

Underground cables must be protected against excessive overheating caused by fault currents. Excessive heating could damage the cable, requiring lengthy and costly repairs. Faults in pipe-type cables may burn through the steel pipe, if the fault is not cleared quickly enough. In addition, radially directed forces on the pipe during prolonged faults can cause weld seam ruptures. These ruptures could cause additional environmental implications because thousands of gallons of insulating oil fluid could leak into the ground.

For these reasons, cable protection must be high speed and typically requires some form of a communications channel between the two ends of the cable circuit. Because most cable faults involve ground initially, ground fault sensitivity is of utmost importance. Therefore, high-speed pilot relaying systems are the most common relaying schemes applied for HV cable protection.

The main problem in protecting cable circuits is the high charging current, which may be an appreciable fraction of the load current, especially in long cable circuits. This limits the choice of minimum fault current settings. In addition, cable circuit energization and de-energization creates high transient currents. The frequency and magnitude of these currents depend on not only the capacitance, inductance, and resistance of the circuit being energized but also the circuit breaker characteristics, namely preinsertion resistors. Similar high transient discharging and charging currents flow in the cable circuit during external fault conditions. The protection systems must be designed to cope with these transient currents and frequencies. Therefore, a current setting of several times the steady-state charging current may be necessary to ensure that the protection system will not misoperate.

Most faults in a cable circuit are permanent, regardless of relay operating speed. Any reclosing is therefore prohibited because it will only cause additional damage. Because a relay system operation on a cable circuit may be caused by a flashover of terminal or other connected equipment, it is important to know what other equipment is located within the protected zone of the cable.

Typically, the protection systems applied in cable protection are similar to the ones applied in EHV overhead transmission lines. However, we must understand the fundamental differences between the two applications to provide proper protection of underground cables.

The three pilot protection schemes applied for cable protection are current differential, phase comparison, and directional comparison.

### A. Current Differential Protection

A current differential protection scheme compares the currents from a local terminal with the currents received through a communications channel from a remote terminal to determine whether the fault is inside or outside the underground cable zone of protection. A current differential scheme can be either a segregated phase or a composite system. The segregated current differential system compares the currents on a per-phase basis. The composite current differential system compares a local and a remote single-phase signal proportional to the positive-, negative-, and zero-sequence current inputs. The current differential scheme provides instantaneous protection for the entire length of the cable circuit.

The current differential scheme is frequently applied to protect cables because this scheme is less dependent on cable electrical characteristics. The current differential scheme requires a communications channel of wide bandwidth to transmit and receive current information to and from the remote terminal. Its availability, therefore, depends on channel availability. The current differential scheme only requires current inputs and cannot by itself provide backup protection. However, modern numerical relay systems have integrated the current differential relaying scheme as part of a full distance protective relay. The current differential scheme requires special security logic to restrain for external faults during current transformer (CT) saturation conditions. The current differential scheme is immune to power swings and current reversal conditions. The relaying settings for current differential schemes are few and easy to compute; however, cable-charging currents and shunt reactor applications in cable circuits must be considered.

### B. Phase Comparison Protection

Phase comparison relaying schemes compare the phase angle between the local and the remote terminal line currents. Therefore, this scheme requires a communications channel to transmit and receive the necessary information to and from the remote line terminal. Like the current differential relaying system, the phase comparison principle depends on communications channel availability. Phase comparison relaying systems are either of the segregated phase or the composite type.

Phase angle comparison is performed on a per-phase basis in the segregated phase comparison system. All other phase comparison systems use a composite signal proportional to the positive-, negative-, and zero-sequence currents to provide protection for all fault types. In this scheme, the composite

signal is passed through a squaring amplifier to obtain a square wave signal that contains phase angle information. The relay compares the local squared signal against the remote squared signals; if the coincidence of the two signals is greater than a certain value, (e.g., 90 degrees) the scheme declares an internal fault condition.

This scheme has been very popular in the past because it has minimal communications channel requirements. Because the current signals contain phase angle information, this scheme is more secure than the current differential scheme for external fault conditions with CT saturation. Although the sensitivity of the phase comparison relaying system is normally lower than that of the current differential relaying system, all other characteristics are the same.

### C. Directional Comparison Protection

Directional comparison schemes compare the fault direction information from both ends of the cable to determine whether the fault is internal or external to the cable zone of protection. Directional comparison schemes use phase distance, ground distance, and zero- or negative-sequence directional elements at each end of the cable circuit.

Directional comparison schemes require a communications channel for the exchange of directional information between terminals to provide high-speed protection for the entire cable circuit. The minimum channel requirements have made this scheme, both blocking and unblocking types, very popular in cable protection applications. Loss of the communications channel only disables directional comparison functions but does not disable directional protection functions for local and remote backup.

Directional comparison schemes require both voltage and current inputs. It is a good practice to avoid using relay elements that depend on the cable characteristics in directional comparison schemes. Ground distance element settings and measurement depend, to a great degree, on the cable characteristics and the ground current return path.

Modern numerical relays have, in addition to ground distance elements, zero- and negative-sequence directional elements available for cable protection. Negative-sequence directional elements provide excellent fault resistance coverage [7]. These elements do not need to be desensitized to the effects of charging current [8].

### D. Distance Relay Application Considerations

Frequently, protection engineers use phase distance and ground distance elements in directional comparison schemes for cable protection. They also use distance elements for Zone 1 instantaneous tripping, as well as Zone 2 and higher zone time-delayed tripping for backup cable protection. Distance relay element application for cable protection requires a good knowledge of cable electrical parameters and a good understanding of the relay technology and any potential limitations.

The positive-sequence impedance of underground cables in  $\Omega/\text{km}$  is much lower than the positive-sequence impedance of overhead lines because the phase conductor spacing in cables is much smaller than the spacing in overhead lines. In some cases, the total cable circuit positive-sequence impedance may be less than the minimum distance relay setting range value.

The cable zero-sequence impedance angle is less than the zero-sequence impedance angle for overhead lines. The zero-sequence angle compensation requires a large setting range that accommodates all possible cable angles.

The underground cable ground current path depends upon the cable sheath bonding and grounding method and any other conducting path in parallel with the cable. All of these factors affect the underground cable sequence impedances, especially the zero-sequence impedance of the cable. Therefore, the computed zero-sequence impedance value is questionable. In pipe-type cables, the zero-sequence impedance varies as a function of the ground fault current level.

Most faults in underground single-conductor cables involve ground. It is therefore important to concentrate on the impedances seen by ground distance relays for faults in the underground cable and faults external to the cable zone of protection. Equation (1) gives the compensated ground loop impedance.

$$Z_c = \frac{V_a}{I_a + k_0 \cdot I_r} \quad (1)$$

where:

$V_a$  = line-to-neutral voltage.

$I_r$  = residual current.

$k_0$  = zero-sequence current compensation factor.

Choosing the correct zero-sequence current compensation factor,  $k_0$ , produces the correct distance measurement in terms of positive-sequence impedance. Equation (2) gives the proper zero-sequence current compensation factor for overhead transmission lines.

$$k_0 = \frac{Z_{0L} - Z_{1L}}{3 \cdot Z_{1L}} \quad (2)$$

where:

$Z_{0L}$  = zero-sequence impedance of the line.

$Z_{1L}$  = positive-sequence impedance of the line.

Note that in overhead transmission lines,  $Z_{1L}$  and  $Z_{0L}$  are proportional to the distance. However, this is not true for underground cables, where the zero-sequence impedance may be nonlinear with respect to distance [9]. The zero-sequence compensation factor,  $k_0$ , for solid and cross bonded cables is not constant for internal cable faults, and it depends on the location of the fault along the cable circuit. Because ground distance relays use a single value of  $k_0$ , the compensated loop impedance displays a nonlinear behavior.

We will look at the compensated loop impedance for a cable with the sheaths grounded at one end only, having a ground continuity conductor installed along the cable run and

grounded at both ends of the cable, and other types of cable grounding arrangements. Fig. 5 shows the system used to calculate the compensated loop impedances at the two ends of the cable.

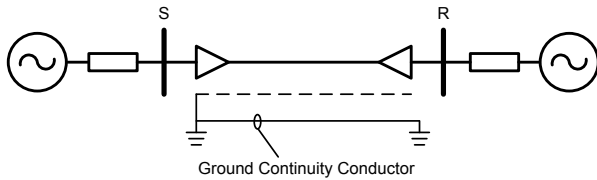

Fig. 5 Single-point bonded cable at Terminal S

The cable in this example is a 1,000 m, 230 kV, single-conductor 1,200 mm<sup>2</sup> copper cable. The positive-sequence impedance of the cable is  $Z_{1c} = 0.018 + j 0.136 \Omega$ , and the zero-sequence impedance is  $Z_{0c} = 0.195 + j 2.166 \Omega$ . The zero-sequence current compensation factor calculated using Equation (2) is  $k_0 = 4.961 + j 0.223$ . Fig. 6 and Fig. 7 show the compensated loop reactance seen by the ground distance relays at the two ends of the cable. Note that a fault at Terminal R is represented at 1 per unit throughout this paper. In other words, fault distance is increasing as we move from Terminal S toward Terminal R.

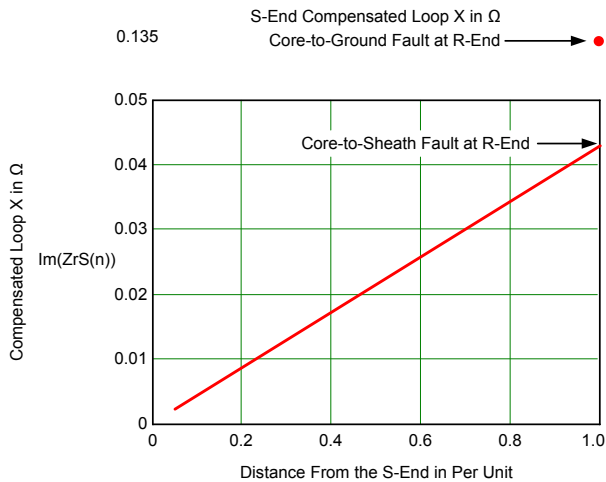

Fig. 6 S-end compensated loop reactance in  $\Omega$  for a single-phase-to-sheath fault on a single-point bonded cable

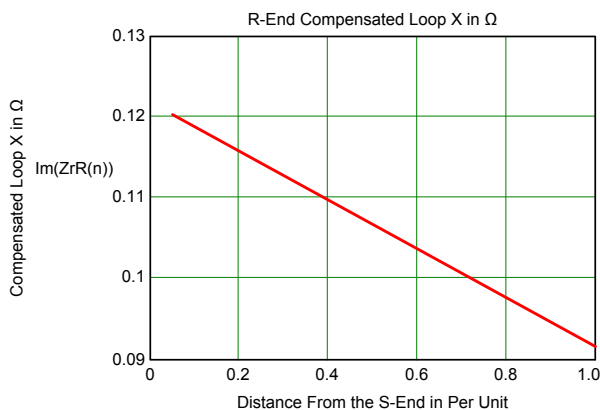

Fig. 7 R-end compensated loop reactance in  $\Omega$  for a single-phase-to-sheath fault on a single-point bonded cable

Note that the compensated loop reactance for a cable with sheaths grounded at the S-end (terminal) only has a linear characteristic similar to an overhead line. This linear characteristic is not like the compensated loop reactance of cables whose sheaths are cross bonded or solidly bonded and grounded at both ends of the cable. Note also that the compensated loop reactance are not the same at the two ends of the cable because of sheath grounding asymmetry.

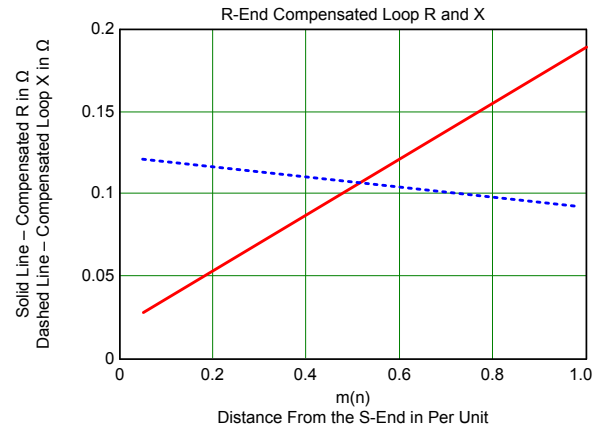

Fig. 8 R-end compensated loop R and X in  $\Omega$  for a single-phase-to-sheath fault on a single-point bonded cable

Fig. 9 shows the compensated loop reactance variation caused by a change in the zero-sequence source impedance.

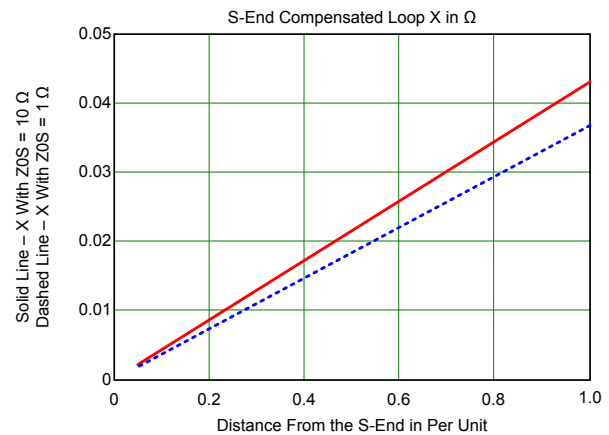

Fig. 9 Variation of the compensated loop reactance at Terminal S caused by a change of the zero-sequence source impedance magnitude

There is a major difference in the impedance seen by the relay at the S-end of the line for a core-to-sheath fault and a core-to-ground fault at the R-end of the cable. For a core-to-sheath fault at the R-end, the impedance seen from the S-end is  $0.138 + j 0.043 \Omega$ , but for a core-to-ground fault, the impedance is  $0.018 + j 0.136 \Omega$ . At Terminal R, for a core-to-sheath ground fault right in front of Terminal R, the compensated loop impedance is not zero and takes on a large value,  $0.189 + j 0.092 \Omega$ . Additionally, the compensated loop resistance at Terminal R decreases as the fault is moved away from Terminal R, as shown in Fig. 8.

The compensated loop reactance measured at Terminal S for a fault at the end of the cable involving sheath return current is only 30 percent of the compensated loop reactance



measured for an external fault at Terminal R. From this analysis, we can conclude that a Zone 1 ground distance relay setting at Terminal S, the terminal where the sheaths are grounded, can be very selective and cover the whole length of the cable. However, relay settings at this terminal for overreaching backup zones must be carefully chosen. In contrast, we cannot successfully apply a Zone 1 ground distance relay at Terminal R. The relay at Terminal R sees a compensated loop impedance discontinuity between a core-to-sheath and a core-to-ground fault at Terminal R but does not see any impedance discontinuity between a core-to-sheath and a core-to-ground fault at the remote terminal.

Next, we look at the compensated loop impedances for the same cable, but with the sheaths grounded at both ends of the cable, as shown in Fig. 10. Note that a ground continuity conductor is present and grounded at both ends of the cable run. Because the sheaths are grounded at both ends of the cable, the compensated loop impedance varies continuously without any discontinuities present between internal and external cable faults.

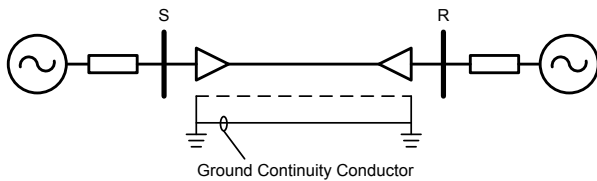

Fig. 10 Solid-bonded cable with sheaths grounded at both ends of the cable

There are two ground fault current return paths for faults that involve the cable core with its own sheath. The first path is directly in the faulted cable sheath. The second path is the faulted cable sheath, the sheaths of the other two cables, the ground, and the ground continuity conductor via the grounding of the sheaths at the cable ends, as shown in Fig. 11.

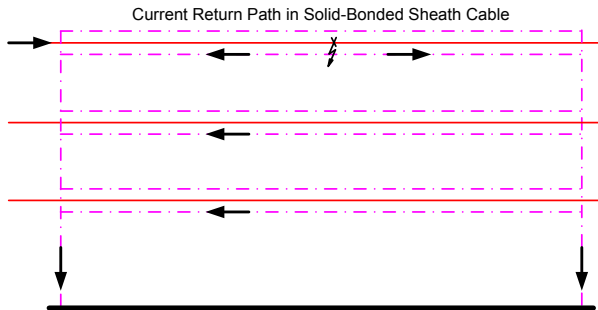

Fig. 11 Paths for ground current return for a core-to-sheath fault in single-conductor solid-bonded cables

The amount of fault current flowing in each return path varies continuously depending on the resistance of each path as the fault location changes along the cable circuit. The continuous variation of the ground current return path causes a nonlinear relation between the fault point and the compensated

loop impedance. Fig. 12 shows the compensated loop impedance nonlinear behavior for ground faults along the cable.

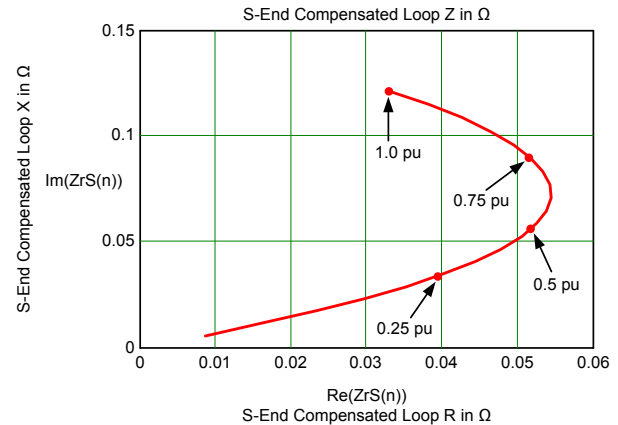

Fig. 12 Nonlinear behavior of compensated loop impedance in solid-bonded cables

Fig. 13 shows the compensated loop reactance obtained with two different compensation factors. The solid line is for a zero-sequence current compensation factor,  $k_0 = 0.79$ , that is used on a typical 230 kV overhead transmission line. The dashed line is for the actual complex zero-sequence current compensation factor,  $k_0 = 0.052 - j 0.287$ , calculated for an external fault for the above cable.

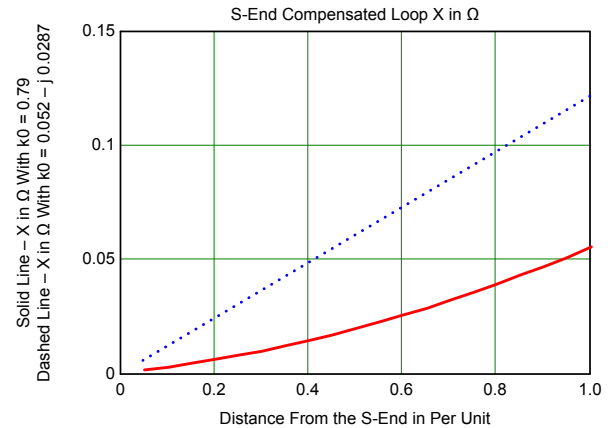

Fig. 13 Compensated loop reactance for different values of zero-sequence current compensation factors

Note that the slopes of the two curves are different, depending on the zero-sequence current compensation factor we choose. The slope variation depends on the particular cable and system studied and cannot be generalized for all single-conductor solid-bonded cables. A steeper slope of the compensated reactance for faults at the remote end of the cable would offer some advantage in setting a Zone 1 ground distance relay, in spite of the small impedance characteristics of single-conductor cables.

In Fig. 14, we plot the nonlinear behavior of the compensated loop resistance at Terminal S as a function of fault distance along the cable in per unit.

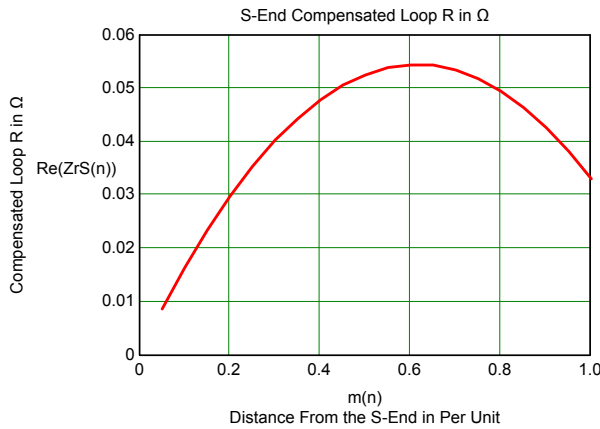

Fig. 14 Compensated loop resistance at Terminal S

Note that in solid and cross bonded cables, the compensated loop resistance is not maximum for a fault at the remote end. The resistive reach, which determines the R/X ratio of the setting characteristic, often presents a problem in underground cable protection. Because the cable has a low characteristic angle, the R/X ratio is critical, and it often leads to pilot schemes because the minimum requirements cannot be met.

Cross bonded sheaths are used more often in longer cable runs where the induced voltage in the sheaths is unacceptable. Longer cable circuits can consist of more than one major section. The voltage induced on the sheaths after three minor sections during load is close to zero. The ground return path in cross bonded cables changes depending on the fault point in the cable circuit. In addition, moving the fault from the end of a minor section to the beginning of the next minor section causes a different return path for the ground fault current and consequently causes a discontinuity in the compensated loop impedance. This discontinuity, shown in Fig. 15, offers some advantage in obtaining selectivity for a Zone 1 setting distance element for faults in the last minor section. Note that the discontinuity is more pronounced when the fault is moved from the first to the second minor section. The cable modeled to generate the data for Fig. 15 consists of three minor sections (i.e., only one major section). However, for longer cable circuits with two or more major sections, the discontinuity tends to be less pronounced as the fault moves to the last minor section.

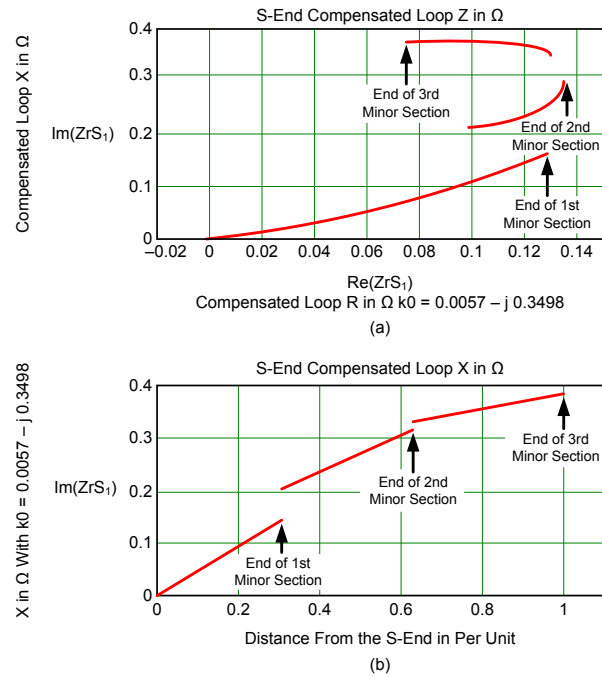

Fig. 15 Compensated loop impedance (a) and reactance (b) for cross bonded cables

The basic philosophy in setting underreaching and overreaching distance relays for underground cable protection is the same as that for setting them for overhead transmission lines. The Zone 1 element should not overreach for faults at the remote terminal, and the overreaching zones should provide protection for the whole cable circuit.

Ground distance elements should measure fault impedance in terms of positive-sequence impedance only. Set the zero-sequence current compensation factor so that the Zone 1 ground distance elements do not see faults external to the protected cable, while the Zone 2 and Zone 3 ground distance elements see all cable internal faults and coordinate with distance relays on adjacent line or cable circuits.

The choice of zero-sequence current compensation factor can influence the reach and the performance of ground distance relays. Choose a zero-sequence current compensation factor that obtains a constant or increasing slope of the compensated loop reactance for faults at the end of the cable. Do this by choosing a complex zero-sequence current compensation factor corresponding to the cable under consideration or by selecting a fictitious scalar ground zero-sequence current compensation factor that would compensate correctly for faults at the end of the cable.

Consider other parameters in addition to the different behavior of the compensated loop impedance, depending on sheath bonding and grounding methods. Network topology plays an important role in selecting settings for underground cable applications. In some applications, parallel cables are installed between two substations. In others, there are mixed overhead and underground sections. Also consider adjacent line sections, whether cables or overhead lines.

For example, in the case of parallel cables, select the proper zero-sequence current compensation factor for Zone 1 by placing a phase-to-ground fault at the remote terminal with the parallel cable out of service. Find the ground distance reactance measurement that does not overreach for that fault using the two zero-sequence current compensation factors that correspond to two different return paths, sheath return only and sheath and ground return. Use all three different cable zero-sequence impedances in the fault study. Select the zero-sequence compensation factor that does not provide any overreach for sheath return alone or for sheath and ground return path.

For the overreaching zones, select the zero-sequence compensation factor so that the ground distance overreaching zones do not underreach for any internal ground faults. Select the zero-sequence current compensation factor that corresponds to the zero-sequence impedance of the cable with ground return only. Place both parallel cables in service, simulate a line-to-ground fault at the remote terminal, and calculate the ground distance reactance measurement for each of the three possible zero-sequence cable impedances.

Modern digital ground distance relay elements offer the user more options in achieving a better performance of ground distance element measurement than do their older electromechanical and static counterparts. They offer more than one complex zero-sequence current compensation factor, with a wide range of magnitude and angle settings, as well as a choice of the ground distance relay polarizing quantity, such as either zero-sequence or negative-sequence current. In general, negative-sequence current polarizing is the preferred choice for cable applications because the negative-sequence network is more homogeneous than the zero-sequence network. In addition, modern digital relays offer a nonhomogeneous correction angle setting to help prevent overreach or underreach for ground faults at a specific fault point by compensating the angle of the reactance line.

Although most of the discussion above was on the ground distance element, phase distance elements could also be affected by large capacitive charging currents. The large charging currents could result in an overreaching effect of a Zone 1 phase distance relay.

Protecting underground cables with distance relays can be quite challenging and difficult to achieve because of cable electrical characteristics, the influence of grounding methods and return currents in the zero-sequence impedance of the cable, the nonlinear behavior of the compensated loop impedance, and the short cable length in many applications. For all these reasons and complexities involved in making the proper settings, most users prefer to protect HV underground

cables using line current differential protection systems or phase comparison relaying systems. Distance relays are typically applied in a directional comparison blocking or unblocking scheme and for backup protection.

Modern digital relays have integrated into one relay box a complete line differential relaying scheme, with full distance protection elements, including communications-assisted protection logic, negative- and zero-sequence directional elements, and a plethora of other overcurrent elements. With modern digital relays, we now have a choice of many different relay elements for the protection of underground cables, some of which may be better suited than others. Supplementing ground-distance elements with negative-sequence directional elements in a communications-assisted tripping scheme provides excellent resistive coverage for high-resistance ground faults, for example, during a flashover of a contaminated pothead. Use of negative-sequence directional elements has also been successful in a directional comparison scheme for the protection of submarine cables [8].

## VI. PILOT CHANNELS

Protective relaying systems used with pilot channels are designed to provide high-speed fault clearing for all internal cable faults. For internal cable faults, simultaneous high-speed clearing of both terminals has several advantages:

- Limits the damage to only a small portion of the cable circuit and its insulation.
- Reduces the time and cost of cable repairs.
- Prevents pipe ruptures in pipe-type cables and insulating fluid spills into the environment.
- Improves transient stability of the power system.

There are several relaying communications media channels available for the protection of HV cables. Today, fiber-optic channels are the most common channels for the protection of underground cables. Electric utilities may have other types of pilot channels available for protection use, such as digital and analog microwave channels, pilot-wire channels, and leased audio tone circuits. In addition, power line carrier channels, using the cable conductor as the communications media, have been successful in high-speed protection of underground cables. Reference [6] discusses the advantages and disadvantages of the different pilot relaying channels.

New channels and digital techniques in communications provide opportunities to advance the speed, security, dependability, and sensitivity of underground cable protection. Sharing a handful of bits directly from one relay to another adds new possibilities for pilot protection, control, adaptive relaying, monitoring, and breaker failure, among others. Direct digital communication between digital relays has the dependability, security, speed, and adaptability needed for blocking, permissive, and direct-tripping applications, as well as for control. Reference [10] provides many details regarding the security, dependability, and speed of modern digital relay-to-relay communications.

In this section, we discuss and compare some of the digital communications channels that might be used in pilot cable protection and control schemes, because most modern digital

relays offer relay-to-relay communications using direct digital channels. Fiber-optic networks and other types of communications links are excellent channels to consider for direct relay-to-relay communications.

#### A. Dedicated Fiber

Perhaps the ultimate digital channel for dependability, security, speed, and simplicity is dedicated fiber optics. Low-cost fiber-optic modems make dedicated fiber channels even more attractive. Often, modems can be powered by the relay, eliminating the cost and loss of availability involved in using separate power sources. Some modems also plug directly into the digital relay, which eliminates a metallic cable. Eliminating the cable and the external power source removes “antennas” for possible electromagnetic interference (EMI) susceptibility. Bit errors are extremely rare on most fiber-optic links. Fiber medium is unaffected by radio frequency interference (RFI), EMI, ground-potential rise, weather, and so on.

#### B. Multiplexed Fiber

Fiber-optic multiplexers combine many relatively slow digital and analog channels into one wideband light signal, making efficient use of bandwidth in the fiber. A direct digital connection between the relay and the multiplexer is more reliable and economical than interfacing through conventional relay contacts to a tone set and into an analog channel on the multiplexer. However, the multiplexer adds a level of complexity that can be avoided by the simple dedicated fiber approach discussed earlier. Fiber-optic networks, such as synchronous optical network (SONET), move large quantities of data at high speed. Many such networks consist of self-healing rings. While the ring is self-healing, the terminal equipment is generally not, so it, and possibly other points, must be considered as possible single points of failure.

#### C. Multiplexed Microwave

New installed microwave systems are also digital, opening new opportunities for direct relay-to-relay communications. Possible equipment failures include multiplexers, radio gear, antenna pointing errors, cabling, etc. Multiplexed microwave communications systems are fairly immune to power system faults.

#### D. Digital Telephone Circuits

Digital lines can be leased from telephone companies and used for pilot protection schemes. A channel service unit/data service unit (CSU/DSU) interfaces the protective relay to the leased telephone line. It receives timing information from the telephone company equipment via the leased line and passes that information on to the relay (for synchronous data) or synchronizes the asynchronous data stream from the relay (for asynchronous data). The CSU/DSU also converts the serial data received from the relay to the proper electrical levels and format.

It is important to galvanically isolate any leased line between the substation and the central office to prevent damage and danger when ground faults produce high voltages

between the substation ground and the telephone exchange. However, isolation does not guarantee that the leased line remains operational during the fault. Ground potential rise or noise coupled from the faulted power line to the twisted pair can produce enough noise on the circuit to cause bit errors or a complete loss of signal.

## VII. CABLE PROTECTION APPLICATIONS

In this section, we look at some complex cable application examples and offer some recommendations for protecting underground cables, including other considerations, such as reclosing in mixed overhead and underground cable circuits.

#### A. Circuit Consisting of Underground Cable Only

For pure cable circuits, which are relatively short in length, the most common form of protection is line current differential. Typically, this example has two line current differential systems, a Main One system and a Main Two system, each with a communications channel connected to separate and independent communications paths. For instance, one may be on a direct buried fiber cable and the second on a multiplexed fiber or a digital microwave communications network. Modern current differential relay systems offer complete distance protection schemes, including relay-to-relay communications capability in two different ports for pilot system and other protection and control applications. Therefore, users could choose to provide additional pilot schemes using distance and negative-sequence directional elements in both Main One and Main Two relays. Overreaching time-delayed zones of distance protection and directional overcurrent elements typically provide backup protection in both Main One and Main Two protection systems.

This application could also have direct transfer tripping for breaker failure conditions on the same digital channels, taking advantage of relay-to-relay communications. Automatic reclosing is not appropriate because the protective section consists of an underground cable only.

#### B. Cable Circuits Terminated Into a Transformer

Quite often, EHV cable circuits terminate in transformers to provide the load to a major metropolitan area. In some applications, the transformers do not have a high-voltage-side circuit breaker, as shown in Fig. 16.

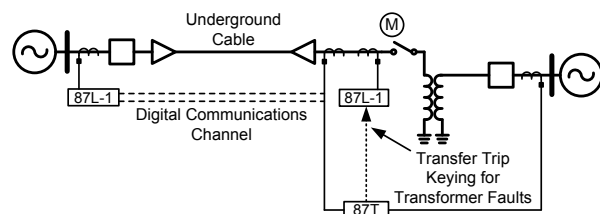

Fig. 16 EHV cable terminated into a transformer

In such applications, the Main One and Main Two cable protection relaying systems could consist of either current differential protection and/or directional comparison protection systems, using phase distance and negative-sequence directional elements for sensitive ground fault

protection. Overreaching time-delayed zones of distance protection and directional overcurrent elements provide backup protection in both Main One and Main Two protection systems. Again, digital communications channels can provide the wide bandwidth required for current differential protection system(s) or for the directional comparison system(s).

There are no high-side circuit breakers at the distribution transformer terminal to trip for transformer faults, so direct transfer tripping of the remote terminal in case of transformer faults is necessary. Typically, this requires two transfer trip channels to ensure that one channel is always available in case of required maintenance or communications system outages.

In these types of applications, we can take advantage of digital relay-to-relay communications and send the direct transfer trip (DTT) bits for transformer faults to the remote station using the same digital channels that are used for the line current differential or the directional comparison system. We can take advantage of digital relay-to-relay communications to eliminate all four sets of transmitters and receivers that would have been required for the cable and transformer protection. This reduces installation and maintenance costs, while at the same time, increasing the reliability of the protection systems.

Likewise, automatic reclosing is not appropriate because the protective section consists of an underground cable only.

### C. Mixed Overhead and Underground Cable Circuits

Applications of mixed overhead and underground cable circuits are very common. Fig. 17 shows a number of circuit arrangements.

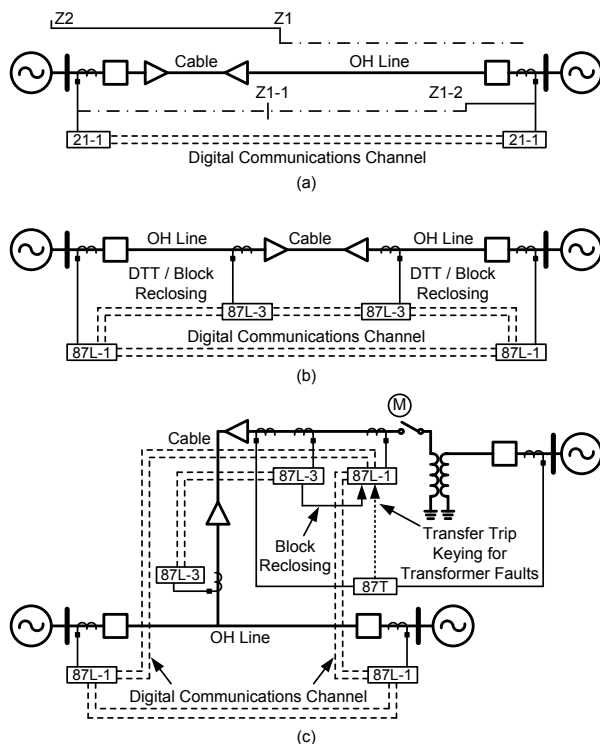

Fig. 17 Mixed overhead and underground circuits

Protection systems for mixed overhead transmission line(s) with underground cables are similar to the protection systems for HV and EHV transmission lines. One important difference from cable circuits is that many users allow high-speed reclosing if the overhead portion of the line length is much greater than the underground cable. Systems where the cable length is less than 15 to 25 percent of the total circuit length usually permit autoreclosing.

Another important factor is whether the cable portion is at the beginning of either terminal or whether it is between two overhead line sections. In Fig. 17a, the cable is at the beginning of the transmission line, and the line length is much longer than the cable section length. In this application, two instantaneous Zone 1 elements are set at the relay near the cable terminal to discriminate between faults in the cable and the overhead line section and to block autoreclosing for cable faults. The first instantaneous Zone 1 element (Z1-1) for the relay near the cable is set at 120 to 150 percent of the cable positive-sequence impedance. Operation of this zone (Z1-1) trips the local breaker and sends a DTT to trip and block high-speed reclosing of the remote terminal. In addition, it blocks high-speed reclosing at the local terminal. The second instantaneous Zone 1 (Z1-2) element of the relay near the cable is set at the typical Zone 1 reach, which is 80 percent of the total cable plus overhead line positive-sequence impedance. For faults in Z1-2 and not in Z1-1, the relay sends a DTT to trip and allows high-speed reclosing at the remote end for single-line-to-ground faults. This application also permits high-speed reclosing for single-line-to-ground faults for the previous condition at the local terminal near the cable.

In Fig. 17a, at the terminal farther away from the cable, the distance relay has only one Zone 1 element. The reach of this element is at 80 percent of the overhead line positive-sequence impedance. Faults detected in this zone trip the local breaker, send a DTT to trip the remote breaker, and allow high-speed reclosing. Faults detected in an overreaching Zone 2 do not permit high-speed reclosing.

If the underground cable is of the pipe type, reclosing may be prohibited altogether unless line current differential relay systems are protecting the cable portion separately, as shown in Fig. 17b. In such a case, we can positively identify that the fault is on the cable circuit and, via communications block, autoreclosing at the two ends of the line.

When the cable is very short (for instance, less than 300 m) and not a pipe-type cable, some users would ignore the cable altogether and allow high-speed reclosing because they assume that the majority of the faults will be on the overhead line section. In some cases, it is economical for short cable lengths to be thermally dimensioned for autoreclosing; however, for longer cable lengths, autoreclosing may or may not be feasible, depending on the thermal rating of the cable.

Fig. 17c shows a three-terminal application in which the cable is protected by a separate line differential system for high-speed detection of cable faults and to block high-speed reclosing at the other two terminals. In Fig. 17, we do not

show the Main Two protection systems. In all three examples of mixed overhead line with cable applications shown in Fig. 17, the protection and reclosing logic is quite complex. However, with modern digital relay communications capability and logic programmability, the task of designing a secure and dependable protection and high-speed reclosing scheme is greatly simplified.

### VIII. CONCLUSIONS

The electrical characteristics of high-voltage underground ac transmission cables are significantly different from those of overhead transmission lines. To adequately protect underground cable circuits, we should do the following:

- Use current differential, phase comparison, and directional comparison relaying schemes.
- Apply directional comparison schemes using distance elements, especially if they are supplemented with negative-sequence directional elements to ensure the required sensitivity for high-resistance faults at contaminated cable potheads.
- Take special care when making ground distance settings, including proper selection of the zero-sequence current compensation factor, because the zero-sequence impedance of the cable is not linearly related to fault distance and is affected by cable bonding and grounding methods.
- Apply modern relays that offer integrated line current differential protection, full distance schemes, negative-sequence directional elements, pilot-scheme logic, and relay-to-relay communication. Functional integration in digital relays offers the most in cable protection.
- Use relay-to-relay communication to create new protection schemes and to combine traditional schemes to reduce costs, increase reliability, and enhance performance of cable protection systems.

### IX. APPENDIX

The single-conductor cable data used throughout the paper include the following:

- Cable type: 230 kV 1,200 mm<sup>2</sup> copper
- Cable length: 1,000 m
- Conductor radius: 2.15 E-02 m
- Insulation radius: 4.52 E-02 m
- Sheath radius: 4.98 E-02 m
- Polyvinyl chloride (PVC) radius: 5.38 E-02 m
- Conductor resistivity: 1.72 E-08 Ωm at 20°C
- Sheath resistivity: 2.14 E-07 Ωm at 20°C
- Permittivity of insulation: 2.5
- Permittivity of PVC: 8.0
- Earth resistivity: 100.0 Ωm

As Fig. 18 shows, the cable conductors are laid in trefoil configuration. Note that the cable sheaths are grounded at both cable ends and there is no ground continuity conductor.

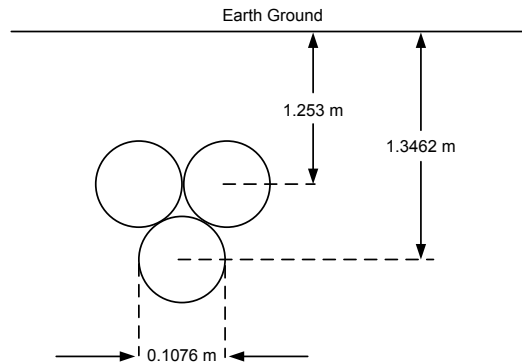

Fig. 18 Cable trefoil configuration

The cable sequence impedances include the following:  
 Cable positive-sequence  $Z_1$  (Ω):  $Z_1 = 0.039 + j 0.127$   
 Zero-sequence conductor  $Z_{0c}$  (Ω):  $Z_{0c} = 0.195 + j 2.166$   
 Zero-sequence sheath  $Z_{0s}$  (Ω):  $Z_{0s} = 0.333 + j 2.091$   
 Zero-sequence mutual  $Z_{0m}$  (Ω):  $Z_{0m} = 0.177 + j 2.092$

To calculate the zero-sequence impedance of the cable,  $Z_0$ , for the three different return paths, we can use the equivalent circuit shown in Fig. 19.

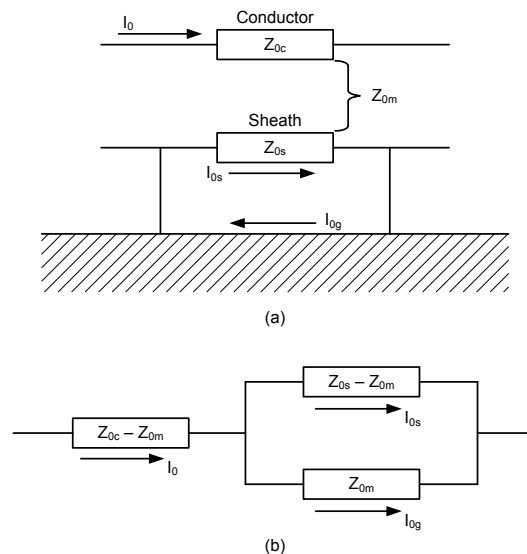

Fig. 19 Zero-sequence return currents and equivalent circuit

The cable zero-sequence impedances for the three possible current return paths are:

1. Current return in the sheath only:

$$Z_0 = Z_{0c} + Z_{0s} - 2 \cdot Z_{0m}$$

$$Z_0 = 0.174 + j 0.073 \Omega$$

2. Current return in the ground only:

$$Z_0 = Z_{0c} - Z_{0m} + Z_{0m} = Z_{0c}$$

$$Z_0 = 0.195 + j 2.166 \Omega$$

3. Current in the sheath and ground in parallel:

$$Z_0 = Z_{0c} - Z_{0m} + \frac{(Z_{0s} - Z_{0m}) \cdot Z_{0m}}{Z_{0s}} = Z_{0c} - \frac{Z_{0m}^2}{Z_{0s}}$$

$$Z_0 = 0.172 + j 0.084 \Omega$$

## X. REFERENCES

- [1] P. L. Ostermann, Editor, *Underground Transmission Systems Reference Book*, New York: Electric Power Research Institute, 1992 Edition, p. 9.
- [2] *IEEE Guide for Application of Sheath-Bonding Methods for Single-Conductor Cables and the Calculation of Induced Voltages and Currents in Cable Sheaths*, IEEE Standard 575-1988, March 1986.
- [3] *Electrical Transmission and Distribution Reference Book*, Westinghouse Electric Corporation, 1964, pp. 64–95.
- [4] J. H. Neher, “The Phase Sequence Impedance of Pipe-Type Cables,” *IEEE Trans. on Power Apparatus and Systems*, Vol. 83, August 1964, pp. 795–804.
- [5] G. Liu, “Computation of Zero-Sequence Impedance of Underground Three-Phase Pipe-Type Cable,” Ph.D. dissertation, Department of Electrical Engineering, Clemson University, Clemson, 2000.
- [6] Working Group D12 of the Line Protection Subcommittee, PSRC, “Protective Relaying Considerations for Transmission Lines With High Voltage AC Cables,” *IEEE Transactions on Power Delivery*, Vol. 12, No. 1, January 1997, pp. 83–96.
- [7] J. Roberts, E. O. Schweitzer, III, R. Arora, and E. Poggi, “Limits to the Sensitivity of Ground Directional and Distance Protection,” proceedings of the 50th Annual Georgia Tech Protective Relaying Conference, Atlanta, GA, May 1996.
- [8] J. Vargas, A. Guzmán, and J. Robles, “Underground/Submarine Cable Protection Using a Negative-Sequence Directional Comparison Scheme,” proceedings of the 26th Annual Western Protective Relay Conference, Spokane, WA, October 1999.
- [9] V. Leitloff, X. Bourgeat, and G. Duboc, “Setting Constraints for Distance Protection on Underground Cables,” proceedings of the Seventh International Conference on Developments in Power System Protection (IEE Conference), Amsterdam, Netherlands, April 2001.
- [10] E. O. Schweitzer, III, K. Behrendt, and T. Lee, “Digital Communications for Power System Protection: Security, Availability, and Speed,” proceedings of the 25th Annual Western Protective Relay Conference, Spokane, WA, October 1998.

## XI. BIOGRAPHY

**Demetrios A. Tziouvaras** received his BSEE from the University of New Mexico and MSEE from Santa Clara University. He is an IEEE Senior Member, a member of the Power System Relaying Committee (PSRC), and CIGRE. He was with Pacific Gas and Electric Co. where he held various protection engineering positions, including principal protection engineer for 18 years. In 1998, he joined Schweitzer Engineering Laboratories, Inc., where he currently holds the position of senior research engineer. He holds four patents and has authored and coauthored more than 50 technical papers. He served as the convener of CIGRE working group B5.15 on “Modern Distance Protection Functions and Applications” and is a member of several IEEE PSRC and CIGRE working groups.