

# IEC 61850-9-2 Process Bus and Its Impact on Power System Protection and Control Reliability

Veselin Skendzic, Ian Ender, and Greg Zweigle  
*Schweitzer Engineering Laboratories, Inc.*

Presented at the  
9th Annual Western Power Delivery Automation Conference  
Spokane, Washington  
April 3–5, 2007

# IEC 61850-9-2 Process Bus and Its Impact on Power System Protection and Control Reliability

Veselin Skendzic, Ian Ender, and Greg Zweigle, *Schweitzer Engineering Laboratories, Inc.*

**Abstract**—This paper analyzes the Sampled Value (SV) Process Bus concept that was recently introduced by the IEC 61850-9-2 standard. This standard proposes that the Current and Voltage Transformer (CT, PT) outputs that are presently hard wired to various devices (relays, meters, IED, and SCADA) be digitized at the source and then communicated to those devices using an Ethernet-Based Local Area Network (LAN). The approach is especially interesting for modern optical CT/PT devices that possess high quality information about the primary voltage/current waveforms, but are often forced to degrade output signal accuracy in order to meet traditional analog interface requirements (5 A/120 V).

While very promising, the SV-based process bus brings along a distinct set of issues regarding the overall reliability of the new Ethernet communications-based protection and control system. This paper looks at the Merging Unit Concept, analyzes the protection system reliability in the process bus environment, and proposes an alternate approach that can be used to successfully deploy this technology. Multiple scenarios used with the associated equipment configurations are compared.

Additional issues that need to be addressed by various standards bodies and interoperability challenges posed by the SV process bus LAN on real-time monitoring and control applications (substation HMI, SCADA, engineering access) are also identified.

## I. INTRODUCTION

High-speed network communications have already changed the world we live in and are poised to bring significant changes to the way we control and operate the power system. To be successful, new technology requires industry-wide agreement on diverse topics such as system architecture, communications infrastructure, data models, and high layer protocols. This agreement is being achieved through industry standards with IEC 61850 and IEEE C37 series have taking the lead role.

It is very important to note that standards are becoming increasingly interdependent and voluminous. For example, the term IEC 61850 currently encompasses 14 individual standards and is further dependent on hundreds of other standards (notably IEEE 802.xx and associated RFC series), which are necessary to ensure open system architecture and individual device interoperability.

This paper focuses on a small segment of IEC 61850 known as the Process Bus or Sampled Values (SV) [1][2][3], defined in IEC 61850-9-2. It looks at the overall system reliability, required standard clarifications, and associated hardware implementation options that may be needed in order to successfully deploy Process Bus technology.

## II. SYSTEM ARCHITECTURE

The process bus idea is relatively simple and can best be explained by looking at Fig. 1. According to Fig. 1, a substation control system is divided into three distinct levels:

- Substation Level
- Bay/Unit Level
- Process Level

Data gathering starts at the process level with Instrument Transformers (IT) whose outputs are immediately sampled, converted to digital representation, and formatted for subsequent transmission through the process bus LAN. The process bus is also used to control high voltage equipment such as breakers, breaker control units, disconnect switches, etc. Process level information is then communicated over the LAN to the protection and control devices that are located at the Bay/Unit Level.

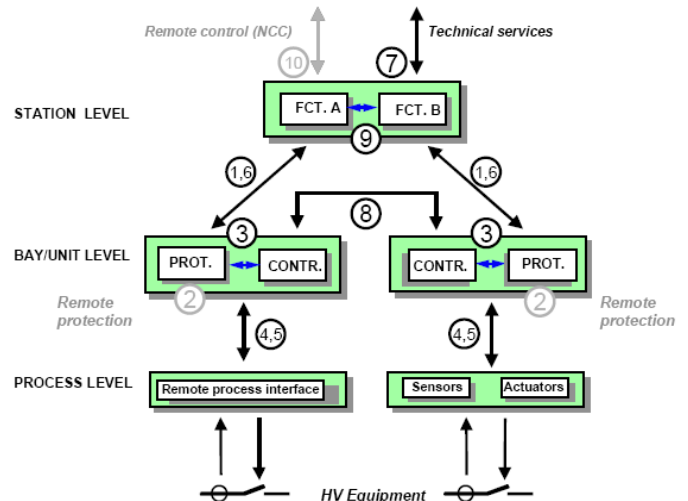

Fig. 1. Levels and logical interfaces per IEC 61850-5

Process bus data exchange is denoted with Numbers 4 and 5 on Fig. 1. Protective functions are to be performed at the Bay Level, while the overall substation-wide coordination, substation Human Machine Interface (HMI), and the SCADA system interfaces are performed at the Station Level [4].

Proposed approach promises to lower the installation cost by significantly reducing the amount of low voltage wiring and replacing it with logical connections established through the process bus LAN [5][6]. Potential savings are most easily visible in the case of an open-air high-voltage yard, which currently requires an extensive network of wiring trenches for bringing a multitude of instrument transformer signals and control wires to a substation control room [7][8].

In the new Process Bus-Based System, yard wiring could potentially be reduced to three rings. The first two rings are dc power distribution rings that ensure a redundant source of energy for the breakers (prime mover) and a third fiber-optic-based Ethernet LAN ring carries the process bus traffic. This approach implies that instrument transformers need to be equipped with built-in Analog-to-Digital Converters (ADC) and appropriate data formatting capability required for generating the SV messages. Instrument transformers that do not have this capability (for example, conventional CTs and PTs) would be connected to yard mounted Merging Units [3] intended to bridge the gap between the analog signal world and the IEC 61850 process bus LAN. A simple illustration of this approach is given in Fig. 2.

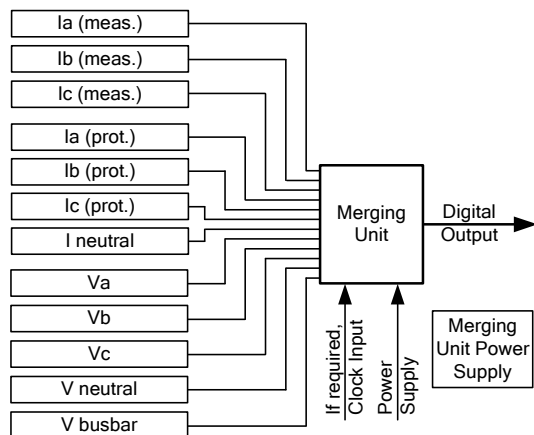

Fig. 2. Merging unit concept per IEC 60044-8

A simplified block diagram of a substation using Sampled Values with the merging unit is shown in Fig. 3.

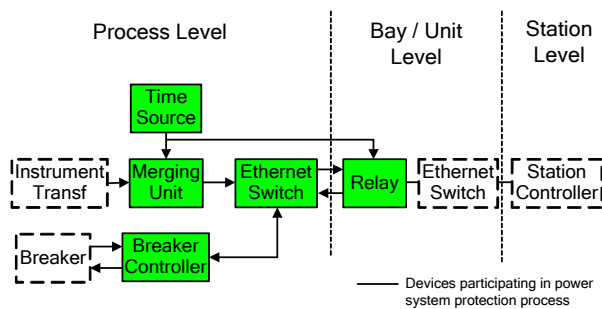

Fig. 3. Simplified substation block diagram indicating core devices and their associated logical levels.

The blocks drawn with solid outlines indicate devices involved in the power system protection process. The most striking characteristic of this picture becomes clear when it is compared to a present-day solution in which all of the protective functions are normally performed by a single microprocessor-based multifunction relay.

The proposed process bus solution introduces four new devices as critical parts of the electric power protection system:

- Merging unit
- Time synchronization source (for multiple SV streams)
- Ethernet switch
- Intelligent breaker controller

This proliferation of the required hardware immediately raises concerns regarding procurement cost and the overall system reliability.

In order to succeed in the marketplace, any new technology must be able to provide tangible benefits to the user who is often satisfied with the performance levels achieved by the current systems and has already invested significant resources in the associated personnel training.

While cost issues can be addressed over time given technology advancements and market competition, system reliability merits additional study. The rest of this paper will attempt to analyze protection system reliability in the process bus environment and propose an alternate approach that can be used to successfully deploy the process bus technology.

In order to simplify our reliability calculations we will use the following assumptions:

- Mean Time Between Failure (MTBF) is equal for all devices.
- Optical fiber connection MTBF is not taken into account.
- Redundancy can be used to mitigate individual fiber failure.
- Instrument transformer and breaker controller MTBF is not included since these devices are assumed to be common in all studied configurations.

The first assumption implies similar hardware complexity for all of the new devices. The assumption is justified by the fact that each of the devices in question typically has a microprocessor, memory subsystem, Ethernet transceivers, power supply components, and is therefore (at least in principle) capable of performing most of the required protective functions as a stand-alone unit.

Optical fiber connections are expected to be more reliable than the current copper wire connections; but if undisturbed, potential exposure of both media will primarily be associated with the number of connections.

The above simplifications are justified by the fact our results are used only to illustrate architectural arguments. For further information regarding detailed reliability calculations, readers are encouraged to read references [9][10][11][12].

For illustration purposes, we will also assume a numeric MTBF value equal to 300 years for all devices, which is relatively close to the level currently exhibited by state-of-the-art protective relays. Actual MTBF numbers for real-life devices will often be lower. For example, 106 years for a substation-grade Ethernet switch with dual power supply, 57 years for a switch with single power supply, or 11.5 years for a commercial-grade switch product.

Another clarification necessary for proper understanding of the examples is the meaning of the word MTBF. A 300 year MTBF does not mean that a single device will operate for 300 years; it only indicates that in a statistical population of 300 devices we can, on average, expect one device to require service action every year.

Upon examining Fig. 3, it is easy to see that all five “solid block” devices need to be online in order for the protection system to be operational. In reliability terms, such a system is modeled as an AND function resulting with a final MTBF of:

$$\frac{1}{MTBF} = \sum_{n=1}^N \frac{1}{MTBF_n} \quad \text{Eq. 1}$$

In our simplified example, with all MTBFs assumed to be equal to 300 years, the calculation for N devices simply reduces to:

$$\text{systemMTBF} = \frac{\text{deviceMTBF}}{N}$$

$$\text{systemMTBF} = 300/5 = 60 \text{ years} \quad \text{Eq. 2}$$

It is immediately obvious that protection and control engineers used to a 300-year observed MTBF are going to have difficulty accepting new technology which has a five times lower MTBF. While redundancy can be used to keep the system operational through individual device failures [13], this approach often doubles the amount of necessary equipment, thus further increasing the number of required service calls and maintenance effort needed to repair or replace failed equipment in the field. A different approach is obviously required.

By looking at Fig. 3 again, it is easy to notice functional synergy between the merging unit and the breaker controller unit. Both functions can conveniently be combined in a single hardware device as shown in Fig. 4. This approach, also illustrated in IEC 61850-9-1, works well with conventional instrument transformers, which are often located on the breaker bushings or in the immediate vicinity of the breaker.

Breaker controller approach may be less appropriate with optical instrument transformers, which are usually located inside the control building.

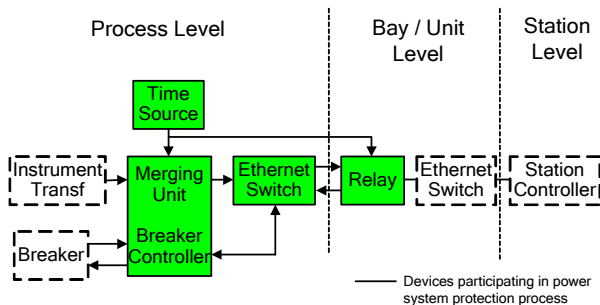

Fig. 4. Merging unit combined with the breaker control

Combining the units results in a system MTBF equal to

$$\text{systemMTBF} = 300/4 = 75 \text{ years} \quad \text{Eq. 3}$$

A 75-year MTBF is still too low but indicates a step in the right direction. An obvious next step would be to combine all protection functions into a single device as shown in Fig. 5.

By combining all protection functions, we were able to lower the number of mission-critical components by eliminating an Ethernet switch and the time synchronization source (at least for simple, single-ended functions such as overcurrent or distance). The resulting protection system reliability returns to a 300-year MTBF. When required, the system can still be used to provide SV data to other clients, such as a revenue meter shown in Fig. 5 or a substation-wide Digital Fault Recorder (DFR).

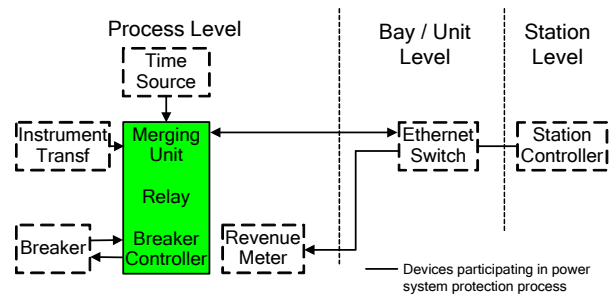

Fig. 5. Merging unit combined with protective relay and breaker control unit

Although appealing at first, the system shown in Fig. 5 is overly simplistic. It does not work in cases of distributed protection schemes such as buss or line differential. Furthermore, all of the discussed configurations run into problems while attempting to address different voltage levels and switchgear configurations. It could even be argued that no single architecture can be made to excel in all application environments such as the following:

- Open-air, high-voltage substation yard
- Gas Insulated Switchgear (GIS)
- Metal clad and metal enclosed switchgear
- Industrial power systems
- High reliability commercial/industrial parks
- Shipboard and marine power systems

A new approach is therefore desired. It must meet the following criteria:

- Must be flexible (tailored to a particular application)
- Cost effective (initial and life-cycle cost)
- Reliable
- Capable of providing tangible benefits
- Able to excel in “Green Field” and “Retrofit” installations

A practical solution to our dilemma can be found by taking closer look at the IEC 61850-5 Standard [4]. The core concept of this standard is the creation of a clear distinction between the physical and the logical world. Four basic building blocks are defined:

- Logical nodes
- Logical connections
- Functions
- Physical devices

A logical node is intended to be the smallest part of a function. Logical nodes exchange data with their peers, and are grouped together into Functions by using various Logical Connections.

Mapping of Logical Nodes and Functions into Physical Devices is totally free and can ideally be optimized to match individual user applications. Multiple functions can be mapped into a single physical device or distributed across multiple devices (thus forming communications-based Distributed Functions) as shown in Fig. 6.

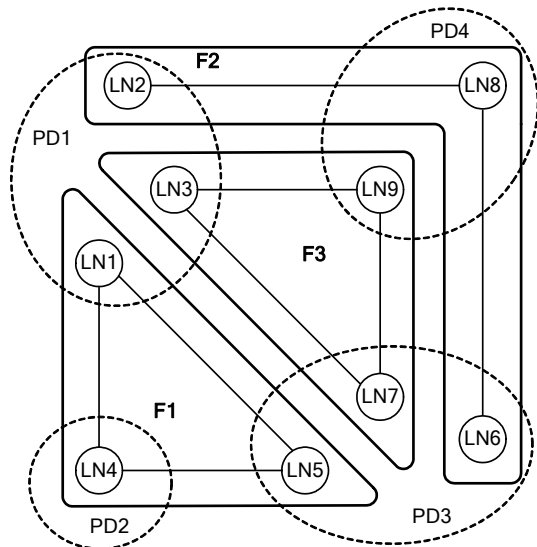

Fig. 6. Illustration of the 61850-5 Logical Node concept

The example in Fig. 6 shows a total of three functions (F1–F3) distributed across four physical devices (PD1–PD4). Each function contains three Logical Nodes (LN), with logical nodes being freely allocated across different physical devices. Logical connections are also eventually mapped to physical connections established over the LAN, with Sampled Values being one of the available transport mechanisms.

Logical nodes [4] are further subdivided into the following six categories:

- Protection
- Control
- Physical devices
- Security
- Primary equipment
- System services

Typical examples of logical nodes include PTOC (time overcurrent), PDIS (distance protection), XCBR (circuit breaker interface), and TCTR (current transformer). IEC 61850-5 defines approximately 100 distinct logical nodes.

The logical node concept can also be used to simplify our Process Bus solution shown in Fig. 5. Instead of approaching implementation from the physical device perspective (as we did in our discussion about merging units), we can start by looking at the optimal location for each of the various protective elements (also called Protection Logical Nodes in IEC 61850 terminology). For example, a simple protective element such as instantaneous overcurrent (IEEE/ANSI device function number 50) requires only one set of three-phase current measurements and would ideally be placed in the immediate vicinity of the circuit breaker. Similar logic applies to the time overcurrent element (IEEE/ANSI device function number 51). By locating these elements in the vicinity of the breaker, we would take advantage of the physical proximity of the instrument transformers and the breaker control mechanism. Wiring would be localized, with dc power and Ethernet LAN being the main connections with the rest of the world. Bringing in additional voltage signals (from nearby PTs) would allow the possibility of adding a distance protection element (IEEE/ANSI device function number 21), creating a fairly

complete protection scheme (also called Function in IEC 61850 terminology) as shown by the “solid line” device in the center of Fig. 7. The new physical device would act as a Merging Unit, Protective Relay, and a Breaker Controller.

More complex protection schemes, such as Bus or Line Differential (IEEE/ANSI function numbers 87B and 87L) would be allocated to a separate physical device (shown with dotted lines in Fig. 7) and fed by multiple SV streams (only one stream shown).

It can easily be argued that line differential and bus differential schemes are inherently dependent on communications for gathering data from remotely located devices. Such functions naturally tend to be centrally located and will inherently depend on a large number of physical connections—all of which must be in service for a protection scheme to operate correctly.

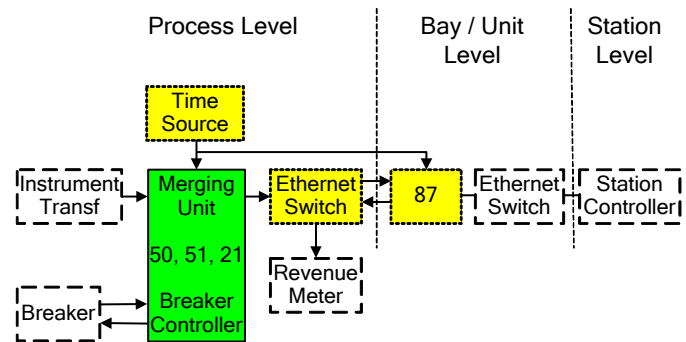

Fig. 7. Process bus-based concept with flexible allocation of distributed protection functions

Our example illustrates how the simple concept of flexible logical node allocation can have a significant influence on the reliability and availability of a given protection element.

The reliability calculations shown in Table I are applicable to Fig. 7.

TABLE I  
MTBF CALCULATIONS FOR INDIVIDUAL PROTECTIVE ELEMENTS

Protective Element	Number of Physical Devices Involved	MTBF
50 (PIOC)	1	300 years
51 (PTOC)	1	300 years
21 (PDIS)	1	300 years
87 (PDIF)	4+	<75 years

Strictly speaking, the number of devices participating in the differential scheme will always be larger than the four indicated in Fig. 7 (including the other end of the line and other bus terminals), with precise calculations going well beyond the scope of this paper.

The main outcome of our analysis is a realization that extended use of Ethernet-based communications and the physical configurability proposed by IEC 61850 brings along a new requirement to analyze overall system reliability. In this new world, shown in Fig. 6, where protective elements can be freely allocated to various physical devices, reliability needs to be calculated on a per protection element and per protection scheme basis.

The final decisions about protective element placement may vary, and will often be optimized to meet particular application constraints. Programmable physical devices capable of hosting a variety of real-time functions will have to be extremely flexible, justifying the name Intelligent Electronic Devices (IEDs) that is becoming so often used in our industry.

### III. SYNCHRONIZATION ISSUES

In order to reach their full application potential, SV streams must be synchronized to a common time reference. At the time this paper was written, the IEC 61850 series of standards recommends the Network Time Protocol (NTP) as the primary synchronization method and recognizes the fact that the NTP time accuracy (0.1 to 1 ms) is insufficient for SV applications which require  $<1 \mu\text{s}$  accuracy. For SV communications, the standard simply allows time to be distributed by independent means, as indicated by the “clock input” shown in Fig. 2.

In present-day installations, microsecond level time synchronization is accomplished by distributing IRIG encoded time signals, or precise one pulse per second timing signal (popular in Europe). On the physical layer, time signal distribution is accomplished using independent coaxial cables or fiber-optic-based distribution networks. Because of ground potential rise, fiber-optic distribution is preferred in open-yard substations.

Regardless of the actual medium used for signal distribution, it is easy to notice that the time synchronization network must be deployed as a separate network, thus adding to the previously described dc power and the LAN networks.

To make things worse, time distribution network reliability is critical for the SV-based process bus operation. Without synchronized time sampling, it is impossible to combine SV outputs generated by multiple physical devices (electronic ITs and merging units).

Unsynchronized SV streams cannot be used to accomplish differential protection, synchrophasor measurements, or digital fault recording functionality. Lack of synchronization may also degrade frequency-tracking capability normally found in modern protective relays.

The above observations leave us with a total of two mission critical networks:

- Process Bus Ethernet-Based LAN
- Time Synchronization Network

Both of these networks must be operational at all times, further reducing the overall system MTBF. Redundancy that can easily be applied to a single network becomes cost prohibitive in the case of two independent networks.

The best way to simplify the time synchronization problem is to use one network for both time distribution and communications functions (similar to the approach used by NTP). The Ethernet-based substation LAN is therefore the obvious candidate.

A single network implementation can be accomplished by using IEEE 1588 “Precision Time Synchronization Protocol” (PTP) [17]. This standard uses bidirectional communications combined with hardware level timestamping to provide precise clock synchronization. It is also capable of compensating for transmission medium delays and offers additional services for automatic election of the best master clock device.

Because hardware assisted functionality is required for sub-microsecond accuracy, IEEE 1588 hardware has to be supported by both Ethernet switches and the end devices. This has resulted in slow adoption of the first version of the standard. At the time this paper was written, the IEEE 1588 working group is finalizing the second revision of the standard. The second revision introduces a large number of new features including transparent clock devices, OSI Layer 2 support, and higher time precision. The new IEEE 1588 revision is gaining support from a wide range of industries such as the silicon chip manufacturers, who are expected to be a crucial factor in lowering the cost of the end solution. At least two microprocessor companies have already released products with hardware-based IEEE 1588 support with additional vendors expected to join with the release of the second version of the standard.

In addition, IEEE 1588 will be included in the next revision of the IEC 61850 standard series, thus fostering its wide deployment in the power system substation environment.

### IV. COEXISTENCE WITH SUBSTATION AUTOMATION

Another important property of the SV-based process bus is its thirst for Ethernet network bandwidth. Reference [2] defines two distinct sampling rates:

- 80 samples per nominal system frequency cycle
- 256 samples per nominal system frequency cycle

In the 60 Hz power system (US) this translates to 4,800 Hz and 15,360 Hz. In terms of Ethernet network loading, these rates translate respectively to 5 percent and 12.3 percent of the 100 Mbps Ethernet link capacities. Although relatively high, these loads can be managed through proper use of high performance managed Ethernet switches, but require a certain level of expertise by the personnel in charge of designing and maintaining the new networks.

In addition to bandwidth constraints, it is also important to note the need to carefully coordinate the extent of the Process Bus LAN segment and the selection of the Layer 2 multicast addresses. Reference [1] provides good guidance and a warning regarding the issue of multicast address aliasing. Unless properly addressed by the system integrator, process bus traffic can easily overload other parts of the substation automation network, causing additional delays in the delivery of SCADA and substation control messages. Where required, multicast domain partitioning can also be accomplished by configuring the Ethernet switch hardware [14].

The decision to use a fully separated process bus or to merge the process bus along with the main substation LAN can be made depending on the actual application requirements.

### V. CONCLUSION

Process Bus technology described in IEC 61850-9-2 offers a variety of new and exciting possibilities in designing the next generation of Ethernet-based protection and control systems. As with any new technology, Process Bus approach raises a distinct set of issues that have to be overcome in order to achieve wide acceptance of this technology.

We are very excited about the possibilities opened by the new standards and have used this paper as an open forum to

discuss steps that are needed to make the IEC 61850 Process Bus technology successful. In our view, Process Bus technology has to do the following:

- Meet or exceed currently accepted reliability levels.
- Be flexible enough to meet customer expectations.
- Allow for the distribution of processing intelligence.
- Have communications-based protection reliability evaluated on a per-function basis.
- Be able to call upon protective relays to act as both process bus data consumers and process bus data sources.
- Provide easy support for both analog (wired) and digital (SV) interfaces.
- Handle a gradual acceptance of Process Bus technology.

This work is also intended to inform users about new terms and technologies being investigated by various standards bodies. All of the technical issues raised in the paper are either already solved or being currently addressed by the incoming standards, thus promising a bright future for the SV-based Process Bus.

## VI. REFERENCES

- [1] IEC 61850-9-2 2004, *Communication Networks and Systems in Substations – Part 9-2: Specific Communication System mapping (SCSM) – Sampled Values Over ISO/IEC 802-3*, First Edition, May 2005.
- [2] IEC 61850-9-2 LE, *Implementation Guideline for Digital Interface to Instrument transformers Using IEC 61850-9-2*, UCA International Users Group.
- [3] IEC 60044-8 2002, *Instrument transformers – Part 8: Electronic current transformers*, First Edition, July 2002.
- [4] IEC 61850-5 2003, *Communication networks and systems in substations – Part 5: Communication requirements for functions and device models*, First Edition, July 2003.
- [5] M. Kosakada, H. Watanabe, T. Ito, Y. Sameda, Y. Minami, M. Saito, S. Maruyama, “Integrated substation systems-harmonizing primary equipment with control and protection systems,” *Transmission and Distribution Conference and Exhibition 2002: Asia Pacific. IEEE/PES*, October 2002.
- [6] R. Gross et al., “Substation control and protection systems for novel sensors,” *CIGRÉ 2000 Session, SC12/23/32*, Paris, France, Aug./Sept. 2000.
- [7] A. Apostolov, F. Auperrin, R. Passet, M. Guenego, F. Gilles, “IEC 61850 process bus based distributed waveform recording,” *Power Engineering Society General Meeting*, June 2006.
- [8] A. Apostolov, “IEC 61850 distributed analog values applications in substation automation systems,” *Power Engineering Society General Meeting*, June 2005.
- [9] E.O. Schweitzer III, B. Fleming, T.J. Lee, P. M. Anderson, “Reliability Analysis of Transmission Protection Using Fault Tree Methods,” *Proceedings of the 24th Annual Western Protective Relay*, Spokane, WA, 1997, [Online], Available at: <http://www.selinc.com/techpapers/6060.pdf>.
- [10] S. Draber, “Reliability-Oriented Design of a Distributed Control System for High-Voltage Switchgear Stations,” *Twenty-Seventh Annual International Symposium on Fault-Tolerant Computing*, Seattle, WA, June 1997.
- [11] P. Zhang, L. Portillo, M. Kezunovic, “Reliability and Component Importance Analysis of All-Digital Protection Systems,” *IEEE 2006 PES Power Systems Conference and Exposition*, Atlanta, GA, November 2006.
- [12] G.W. Scheer, D. Dolezilek, “Comparing the Reliability of Ethernet Network Topologies in Substation Control and Monitoring Networks,” *Presented at Western Power Delivery Automation Conference*, Spokane, WA, April 2000, [Online], Available at: <http://www.selinc.com/techpapers/6103.pdf>.
- [13] M. Galea, M. Pozuoli, “Redundancy in substation LANs with the rapid spanning tree protocol,” RuggedCom Inc.
- [14] V. Skendzic, R. More, “Extending the Substation LAN Beyond Substation Boundaries: Current Capabilities and Potential New Protection Applications of Wide-Area Ethernet,” *Presented at Western Power Delivery Automation Conference*, Spokane, WA, April 2006, [Online], Available at: [http://www.selinc.com/techpapers/6231\\_ExtendingtheLAN\\_VS\\_03-03-06.pdf](http://www.selinc.com/techpapers/6231_ExtendingtheLAN_VS_03-03-06.pdf).
- [15] V. Skendzic, A. Guzman, “Enhancing Power System Automation Through the Use of Real-Time Ethernet,” *Presented at DistribuTECH, San Diego*, February 2005, [Online], Available at: [http://www.selinc.com/techpapers/6188\\_EnhancingPower\\_20041114.pdf](http://www.selinc.com/techpapers/6188_EnhancingPower_20041114.pdf).
- [16] E. Udren, D. Dolezilek, “IEC61850: Role of Conformance Testing in Successful Integration,” *Presented at Western Power Delivery Automation Conference*, Spokane, WA, April 2006, [Online], Available at: [http://www.selinc.com/techpapers/6242\\_61850Role\\_DD-EU\\_20060519.pdf](http://www.selinc.com/techpapers/6242_61850Role_DD-EU_20060519.pdf).
- [17] IEC 61588-2004 (IEEE 1588-2002), dual logo standard, “Precision clock synchronization protocol for networked measurement and control systems,” September 2004.

## VII. BIOGRAPHIES

**Veselin Skendzic** is a Principal Research Engineer at Schweitzer Engineering Laboratories in Pullman, Washington. Veselin earned his BSEE from FESB, University of Split, Croatia; his M.Sc. from ETF, Zagreb, Croatia; and his Ph.D. from Texas A&M University, College Station, Texas. Veselin has over 20 years of experience in electronic circuit design, has lectured at FESB, and spent over 17 years working on power system protection related problems. Veselin is a senior member of IEEE, has authored multiple technical papers/patents, and has contributed to four IEEE standards. Veselin is an active member of the IEEE Power System Relaying Committee (PSRC) and a Vice-Chairman of the PSRC Relay Communications Subcommittee.

**Ian Ender** is a Hardware Engineer at Schweitzer Engineering Laboratories in Pullman, Washington. Ian graduated with a BS in Computer Engineering in 2005 from Washington State University. He is also a member of the IEEE.

**Greg Zweigle** earned his BS in Physics from Northwest Nazarene University and his MS in Electrical Engineering from Washington State University. He is presently a Senior Research Engineer at Schweitzer Engineering Laboratories in Pullman, Washington. He holds patents in the areas of signal processing and data compression and is a member of the IEEE and the ACS.