

Case Study: Using Distribution Automation to Build the Next Generation Utility in the City of Wadsworth

Mark Feller, P.E.
City of Wadsworth

Bryan Fazzari, Robert Van Singel, and William C. Edwards Jr.
Schweitzer Engineering Laboratories, Inc.

© 2014 IEEE. Personal use of this material is permitted. Permission from IEEE must be obtained for all other uses, in any current or future media, including reprinting/republishing this material for advertising or promotional purposes, creating new collective works, for resale or redistribution to servers or lists, or reuse of any copyrighted component of this work in other works.

This paper was presented at the 67th Annual Conference for Protective Relay Engineers and can be accessed at: <http://dx.doi.org/10.1109/CPRE.2014.6799004>.

For the complete history of this paper, refer to the next page.

Published in
*Wide-Area Protection and Control Systems: A Collection of
Technical Papers Representing Modern Solutions, 2017*

Previously presented at the
68th Annual Georgia Tech Protective Relaying Conference, April 2014,
67th Annual Conference for Protective Relay Engineers, March 2014,
12th Annual Clemson University Power Systems Conference, March 2013,
and DistribuTECH Conference, January 2013

Originally presented at the
14th Annual Western Power Delivery Automation Conference, March 2012

Case Study: Using Distribution Automation to Build the Next Generation Utility in the City of Wadsworth

Mark Feller, P.E., *City of Wadsworth*

Bryan Fazzari, Robert Van Singel, and William C. Edwards Jr., *Schweitzer Engineering Laboratories, Inc.*

Abstract—The City of Wadsworth, Ohio, is upgrading and adding new capabilities to its protection and control (P&C) system. A cohesive set of ground-breaking new technologies is being deployed, leveraging an existing fiber-optic communications network. The integration of modern recloser controls, capacitors, regulators, and feeder circuits with a centralized automated fault detection, isolation, and restoration system is the focus of the new P&C system. In addition, the new P&C design provides a solution to a present challenge: engineering a centralized automated feeder voltage profile optimization solution that can remain fully functional alongside a fault detection and isolation system that is capable of automatically modifying the distribution system topology. The problem with many existing automated voltage profile optimization solutions is that they may need to be disabled when a distribution feeder is not in its normal configuration. These two technologies are being integrated into a single interdependent solution that provides the city with a volt/VAR control system that can automatically and appropriately adapt to constantly changing distribution system topology as faults, loss of potential, miscoordinations, or overloads occur and are automatically and immediately mitigated.

I. INTRODUCTION

In the majority of cases, when a city or utility brings in automation engineers to work on substations or field devices, the protection equipment and settings are already in place. An automation engineer must learn how to work with and around preexisting equipment installed and configured by the engineers who came before. It is usually with great excitement, then, that an automation engineer has the opportunity to be involved in the upgrade of the entire distribution protection and control (P&C) system of a city from the very beginning.

Such is the case with the City of Wadsworth, Ohio. With a closely integrated power and communications department, the city owns a fiber-based high-speed network providing mission-critical communications services to the electric utility. This network is being extended to fulfill the communications needs of new distribution automation (DA) technologies.

These technologies illustrate the advantages that can be realized when known concepts are combined into a more

dynamic and flexible solution. Volt/VAR control can be used to achieve several different goals, including voltage profile optimization, conservation voltage reduction (CVR), and power factor correction [1]. However, its application can be somewhat rigid in that it tends to be unable to adapt to changes in feeder length or, worse, its settings are unable to handle topology changes that cause a device to suddenly belong to another feeder entirely.

These automated changes in system topology also cause problems with trip blocking schemes, such as the IEC 61850 Generic Object-Oriented Substation Event-based (GOOSE-based) blocking scheme being deployed in the recloser controls in the City of Wadsworth. This paper describes how these two technologies have been integrated into an automated fault detection, isolation, and restoration (FDIR) scheme to provide the city with both an effective volt/VAR control system and a dynamic, system-wide, high-speed trip blocking scheme that can be flexible and continue functioning as the system topology changes.

II. PROJECT OVERVIEW

Many pieces of equipment went into the upgrade of the city P&C system. Because automation was designed into the entire project, this equipment can efficiently serve both its primary protective purpose as well as play a part in providing a clear real-time picture of what is happening throughout the system. All communication with these devices takes place via the city fiber-optic infrastructure, which consists of many point-to-point fiber runs, as well as a gigabit ring around the city that makes a stop at every substation.

A. Equipment Upgrade

Five substations were involved in the upgrade process, all of which were similar as far as equipment, protection functions, and communications needs go. The city substations conform to a standard design. Each is fed from a loop source and is a two-transformer, two-distribution-bus station with a normally open bus tie. Each station has four feeders, and each feeder has its own individual voltage regulator (see Fig. 1).

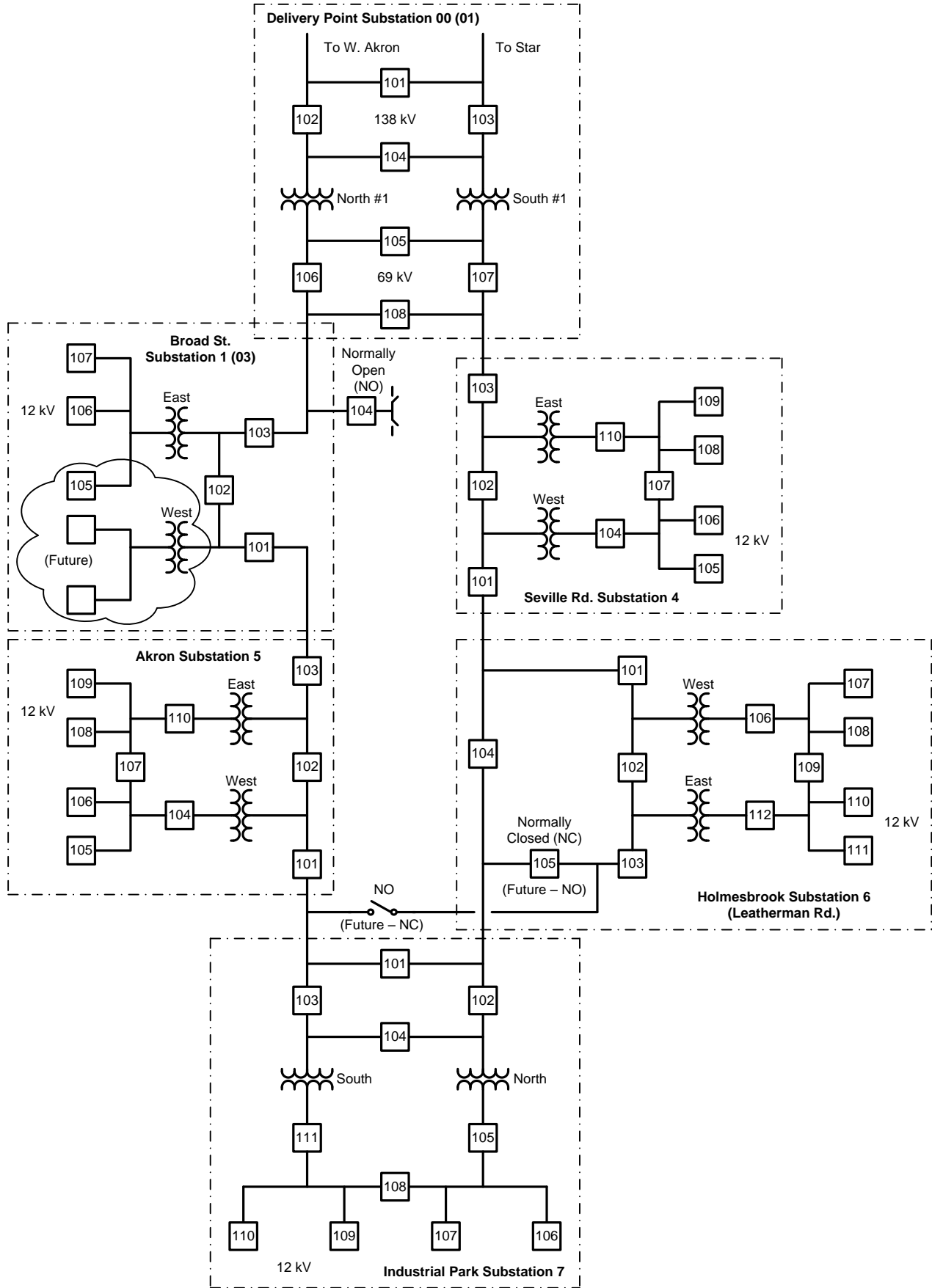

Fig. 1. City of Wadsworth system one-line diagram showing 69 kV loop feeding all five distribution substations. Each substation has two transformers, four feeders, and voltage regulators on each feeder.

Each substation was retrofitted with the following:

- Transformer monitors
- Transformer differential relays
- Main breaker relays
- Bus-tie relays
- Feeder breaker relays
- Capacitor bank controls
- Voltage regulator controls
- Substation human-machine interface (HMI)
- Network firewall
- Remote engineering access

Reclosers with dual-side voltage sensing were added in 24 different locations throughout the system, and existing switched capacitor banks were fitted for new controls that would allow remote control.

B. New Equipment Creates New Possibilities

Having the capability to monitor and control switching devices in the field, such as recloser controls or sectionalizers, opens the door to automatic centralized control techniques, such as automatic FDIR. This technology minimizes outages by isolating a permanent fault to the extent possible and re-energizing unfaulted line segments that were de-energized as a consequence of a recloser or breaker lockout (see Fig. 2 and Fig. 3).

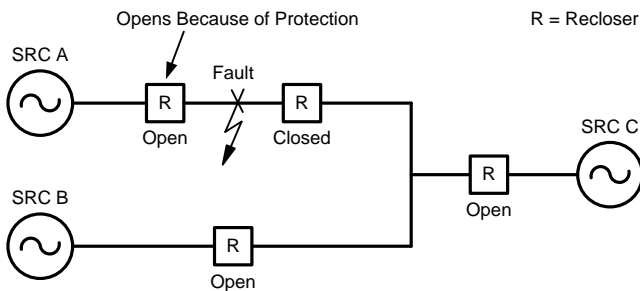

Fig. 2. Permanent fault on the system causes the upstream recloser to open and lock out. All downstream line segments are de-energized.

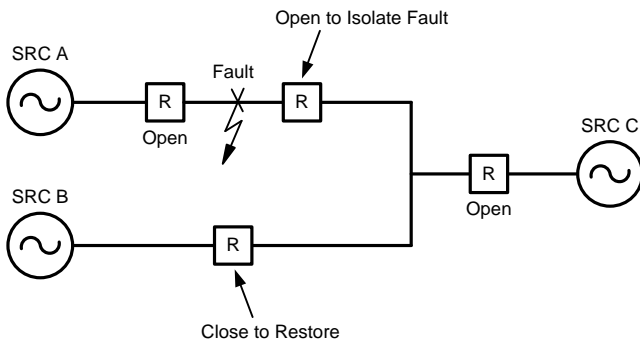

Fig. 3. Fault is isolated, and power is restored to downline customers who experienced an outage but whose line segment was not faulted.

There are two methods of implementing this type of DA: distributed and centralized. The distributed method places the decision-making algorithm in the recloser or switch cabinets and substations, usually organizing them into small working groups that provide coordinated switching. This makes for a robust system in the sense that if one group loses

communication with individual members, it does not affect the other groups in the system. Its disadvantages are that it requires a reliable peer-to-peer communications link and is unable to make decisions based on the condition of the system as a whole.

The centralized method, which was chosen for this application, places all of the intelligence in a single location and polls each field device for data from this location. The advantage of this specific application is that the FDIR system has the opportunity to take any measured parameter of the system into account when making decisions. It is able to observe any voltage sag occurring during heavy loading conditions, as well as the available margins on every monitored device in the system (see Fig. 4).

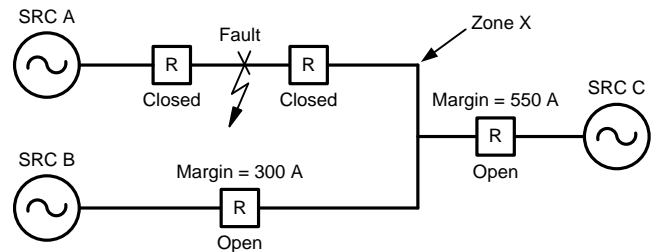

Fig. 4. SRC C is chosen over SRC B to restore Zone X due to a greater current margin, where margin = rated capacity – real-time current loading.

The margins depicted in Fig. 4 are the result of real-time calculations that take into account several different pieces of information, including the following.

1) Transformer Monitors

Variables, such as winding temperature, ambient temperature, cooling fan status, time of day, and weather season, all affect the available capacity of a transformer. The transformer monitors used in this project employ any of these data that are available (this varies from substation to substation) to calculate a total available capacity that is provided to the FDIR logic in real time.

2) Main and Bus-Tie Breakers

Currents are collected from the main relays and used as real-time transformer loading values. Breaker statuses from both of the mains and the bus tie are used to determine which feeders each transformer is responsible for supplying. If a main is open and a tie is closed, changes in feeder length due to an automatic reconfiguration on the system could overload a transformer if this information is not taken into account.

3) Feeder Breakers, Reclosers, and Switches

Voltage, current, breaker status, lockout indication, overcurrent fault indication, and other device status information are collected from each of the feeder breaker and recloser relays. Voltage is monitored to avoid sag due to heavy loading and checked after each switching operation through the course of a restoration. Current is memorized so that loading margin calculations can be made when a fault occurs to determine the best route for restoring power, where possible, without placing an undue burden on other feeders and transformers.

Manual switch status is incorporated into the FDIR logic with indications controlled from supervisory control and data acquisition (SCADA). Knowing these statuses maximizes the effectiveness of the FDIR system reconfiguration capability by allowing it to use alternate feeders that may be connected to the faulted feeder only by a manually operated switch. The SCADA operator is able to directly affect the FDIR system by changing the status of a manual switch when a switching order is created.

III. INTEGRATED VOLT/VAR CONTROL

Volt/VAR control is not a new concept. It is generally implemented on a feeder-by-feeder basis and involves transformers with load tap changers, voltage regulators, and switched capacitor banks.

A. The Purpose of Volt/VAR Control

With the ever-increasing demands placed on the power grid by electronic and motorized devices, the demand for reactive power has grown, as has sensitivity to voltage magnitude. This has created an increased need for precise volt/VAR control on distribution feeders, as well as the ability for distribution systems to provide emergency VAR support to the transmission system.

Also, the City of Wadsworth is a municipal utility that does not have generating capability and therefore purchases wholesale power at a relatively high cost. Because of this, there is a need to optimize distribution system operation in order to reduce power consumption and losses, as well as avoid contractual costs related to reactive power demand. These volt/VAR control goals are met by implementing several different capabilities.

1) Voltage Profile Optimization and CVR

Every feeder has a voltage drop across it. The slope of the voltage drop from the source to the end of the line is referred to as the voltage profile. As the feeder becomes more heavily loaded, the current magnitude increases, which increases the voltage drop due to line impedance. As shown in Fig. 5, the greater the line current, the smaller the voltage at the end of the line V_L (source voltage V_S remains constant).

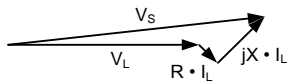

Fig. 5. Finding the sum of the end-of-line voltage V_L and the multiplication of the line current I_L and the line impedance ($R_L + jX_L$) provides the voltage at the source of the feeder V_S .

Utilities must provide a relatively constant voltage to their customers. The steeper the voltage profile becomes, the easier it is to see that it is impossible to provide every customer with precisely the same voltage magnitude; the voltage magnitude the customer receives is a function of where the service hookup is in relation to the feeder length. The goal, then, is to provide every customer with a voltage magnitude that is acceptable, which is typically defined to be ± 5 percent of nominal.

Constant impedance loads consume less energy at lower voltages. Additionally, inductive loads with transformers or lightly loaded motors consume less energy without a loss in performance if their supply voltage is lowered slightly [2]. This can result in an energy savings for the utility without creating a quality of service problem for the customer. Known as CVR, this energy savings is achieved by reducing the lowest point of the voltage profile close to the -5 percent bandwidth edge (114 V). CVR has been made possible in the City of Wadsworth because of the voltage-sensing capabilities of the new reclosers (paired with a city-wide fiber-optic network) that allow the volt/VAR control system to see a clear picture of the entire system.

Voltage profile optimization with CVR acts to flatten the voltage profile and place it in the lower part of the acceptable voltage bandwidth. It flattens by connecting VAR supplies (switched capacitor banks) to the system. By adding shunt capacitance, the overall reactance of the feeder load is decreased, which reduces the voltage drop across the line. Voltage regulators are used close to the substation to raise or lower the entire feeder voltage profile.

2) Power Factor Correction

Most distribution feeder load has an inductive component. Increases in inductive loading cause an increase in lagging power factor. This increase results in a loss of energy for the utility because of increased VAR demand. Volt/VAR control systems can be used to correct the feeder power factor, which provides cost savings to the utility. Power factor correction is accomplished by connecting VAR supplies (switched capacitor banks) to the system as close to the load demand as possible.

B. The Challenge: Volt/VAR Control With FDIR

Most previous discussions about volt/VAR control have concentrated on a feeder-level implementation. In many cases, assuming that the bus voltage regulation is rigid, this works well. However, when a volt/VAR control system is used in concert with an FDIR system, one of two options must be chosen. Either disable volt/VAR control on a feeder that has been reconfigured by the FDIR system or integrate the volt/VAR control system into the FDIR system, allowing them to share information and be aware of each other. The latter option was chosen for the City of Wadsworth, and it made available several new volt/VAR control capabilities.

1) Reactive Power Support

With a system-wide volt/VAR control system, it is possible for an operator to specify the number of VARs needed by the transmission system at the delivery point in the event of an emergency. The system is designed to control to a set point at the transmission delivery point without violating any of the feeder- or device-level voltage or power factor constraints.

2) Voltage Support for FDIR Reconfiguration

When a fault occurs, the FDIR system evaluates all available sources for restoration of unfaulted line segments. If a volt/VAR control system is active on any of these feeders,

the voltage at the end of the line may be close to the bottom of the acceptable voltage magnitude bandwidth (especially if CVR is being used). Even if the FDIR system determines that there is plenty of available source supply margin on the feeder, adding extra load to the end of the feeder could result in an unacceptable voltage sag. In the past, the solution has been that the FDIR system sends a command (per feeder) to the volt/VAR control system to disarm it and proceeds with reconfiguration (while watching the voltage at each device) once the FDIR system receives confirmation. By combining FDIR and volt/VAR control into a single system, the two functionalities can cooperate. If more voltage is needed at the end of the feeder, the FDIR system can request a vertical shift of the feeder voltage profile, and the volt/VAR control system can oblige as long as no voltage constraints are violated. Once the FDIR system completes restoration, the volt/VAR control system can reevaluate the feeder with its new length and optimize the voltage profile as needed.

3) *Adapt to Changing System Topology*

The presence of an FDIR system on the distribution network introduces some important complexities into the volt/VAR control algorithm. It creates the possibility that feeders can change length and complexity in a great number of variations. An adaptive volt/VAR control system must be able to account for these changes and modify its set point as needed.

Historically, line drop compensation (LDC) has been used to achieve adequate voltage regulation as feeder load changes. The regulator taps up and down based on voltage and current measurements and a modeled impedance between the measurement point and the regulated point on the feeder. This method assumes that the feeder length is fixed. With an FDIR system, this is no longer true.

A reconfiguration due to a fault can result in a lengthening or shortening of feeders as extra load is picked up. This adds load to the end of the line and changes the voltage profile. If CVR is being performed, this load could experience an undervoltage condition and the settings of all of the individual volt/VAR devices on the feeder will no longer produce a correct result to all customers on the feeder. In the absolute worst case, a reconfiguration could occur such that a switched capacitor or regulator on the feeder becomes part of another feeder because of a movement of one of the system normally open switches or reclosers. This device, if programmed as a standalone device based on a calculated system model, performs in a way that is inappropriate for the new feeder arrangement.

The system-wide volt/VAR control system designed for the City of Wadsworth solves that problem. With many voltage measurement points and a clear understanding of system topology (as shared by the FDIR system), the centralized

solution can adapt its algorithm, moving a device from feeder to feeder inside the centralized solution logic as it occurs in the field, which maximizes device efficiency.

4) *Volt/VAR Control System Implementation*

The City of Wadsworth is not a large city (it has a population of about 20,000), and there was no great need to maintain a detailed system model. It was important that the volt/VAR control system not place system model maintenance demands on the city that would otherwise not exist.

The solution chosen uses detailed impedance values for substation transformers and identifiable specific spot loads on the system. System impedances for close-in faults and system loading can also be incorporated, but an observe-and-adapt control method augments assumed system characteristics by giving the volt/VAR control system a method of learning the system response to control actions by monitoring the change in V and Q at every measured point. This information is used as feedback into the system decision-making process, making each future control decision more accurate than the last.

IV. DYNAMIC TRIP BLOCKING

The City of Wadsworth uses a very short maximum trip delay at the substations. Traditional timed coordination of all feeder devices became impossible due to the number of recloser controls being added. Because the entire city distribution system was being upgraded at one time, it was possible to leverage the availability of fiber on the lines to implement a high-speed communications-based trip blocking scheme.

Such a scheme needed to be fast and able to work over an Ethernet network. In order to coordinate all devices on the feeder, it was necessary to extend this trip blocking scheme past the substation fence and into the recloser cabinets. The decision was made to put additional logic controllers in each recloser cabinet. Each logic controller uses IEC 61850 GOOSE to multicast its blocking signal over an Ethernet network compartmentalized into virtual local-area networks (VLANs). GOOSE is a Level 2 multicast protocol that uses the extended Ethernet message frame. This extended message frame allows a VLAN identification (ID) to be sent along with every message. The VLAN ID is read by Ethernet switches, which then confine the message to a defined network area. This reduces unnecessary traffic throughout the network. GOOSE messages can also be prioritized by an Ethernet switch, which allows them to be placed in a high-priority queue, bypassing any lower-priority buffering that may be occurring on any given port. Additionally, because they are Layer 2 full-duplex communications, GOOSE messages do not experience delay due to retransmission after an Ethernet collision (there are no Ethernet collisions) [3].

Through the course of evaluating GOOSE as a possible solution to be used by the City of Wadsworth, timing tests were performed. A satellite-synchronized IRIG-B time source was used to synchronize the clocks of two of the recloser controls, and a test setup was constructed (see Fig. 6).

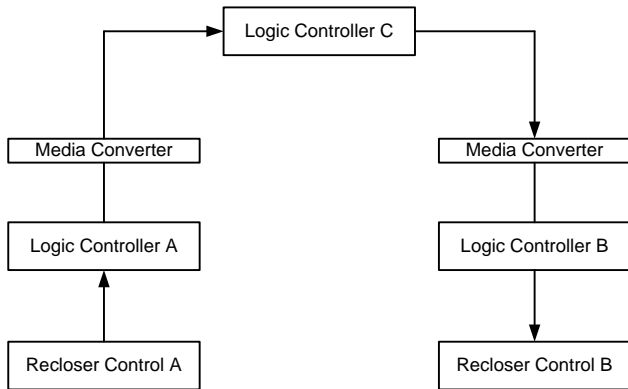

Fig. 6. GOOSE timing test setup.

The recloser controls were connected to the logic controllers via EIA-232 serial cables and the logic controllers were connected to the media converters via copper Ethernet ports. The media converters allowed the use of a single strand of fiber (as opposed to two strands) by using two frequencies of light. Logic Controller C was placed in between the two recloser control cabinets to ensure that no significant delay was added by the presence of a switch device (the two copper Ethernet ports on the back of Logic Controller C were operating in switched mode).

A signal was triggered from the use of a front-panel pushbutton, transmitted from Recloser Control A to the logic controller via serial cable, and packaged into a GOOSE message. The GOOSE message contained one analog and one binary data object. The GOOSE message was multicast out through Logic Controller C and was received by Logic Controller B. It was then converted back into a serial signal and sent to Recloser Control B.

The logic controllers are also polled via DNP3 to collect data for the FDIR and master SCADA systems. In order to stress the equipment as much as possible, the test technicians implemented the expected DNP3 map and added another logic controller (not shown in Fig. 6) to send an integrity poll (requesting this DNP3 map) to each logic controller once a second.

The test was performed every 20 cycles for one minute, after which the sequence of events report was downloaded from each recloser control and the time difference was compared and plotted.

The timing test results in Fig. 7 show that total signal travel time, including conversion from a serial protocol to an Ethernet protocol and back again, was on the order of 1.4 cycles, peaking at 1.68 cycles. This time was sufficient for the project trip blocking needs.

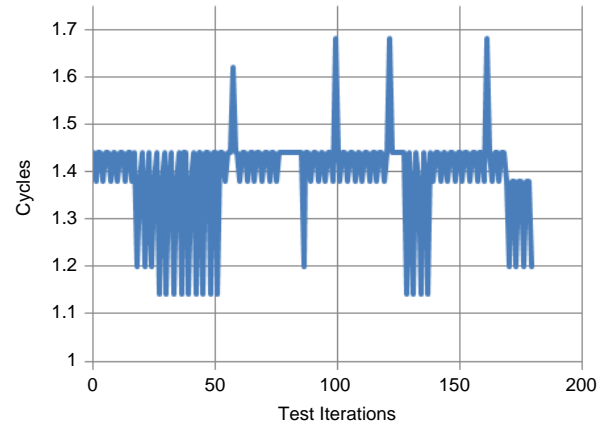

Fig. 7. Plot of GOOSE timing test results.

A. Surprise: FDIR Makes Trip Blocking More Complex

Having an FDIR system that can cause reclosers to change feeders (because of a moving normally open point) creates challenges in a trip blocking scheme design. Not only can the recloser change feeders but the flow of power can reverse after a system reconfiguration. This has the following effect: it is impossible for a recloser control to know which blocking signals to act upon unless there is a centralized device that can take a look at the system topology and tell the recloser control. It was decided that there was no better candidate to perform this centralized task than the FDIR system itself.

The logic controller located in each recloser cabinet needed to be able to differentiate between blocking signals that should be passed on to the recloser control and blocking signals that should be discarded. Because GOOSE is a multicast protocol, the only way to control whether a GOOSE message is received or not is to subscribe to it. Therefore, each logic controller subscribes to the GOOSE messages of every potential adjacent device.

Fig. 8 provides an example of a typical distribution feeder structure, with multiple potential devices upline and downline of Recloser A. This diagram does not show nontelemetered switches that would provide the radial sectionalization for this feeder. The switches are not part of the trip blocking scheme because they do not trip when a fault occurs.

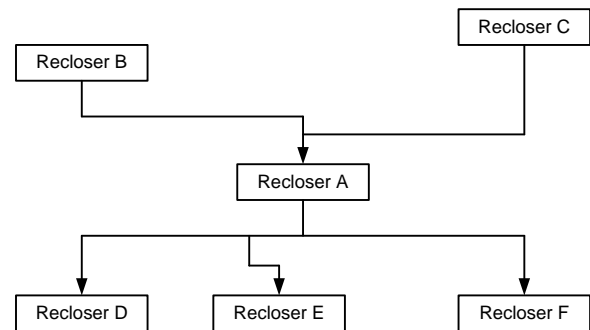

Fig. 8. Typical distribution feeder segment illustrating the number of devices that might exist adjacent to Recloser A.

The arrows in Fig. 8 indicate that the logic controller in Recloser A should be passing along blocking signals from Reclosers D, E, and F, but ignoring any blocking signals received from Reclosers B and C (see Fig. 9).

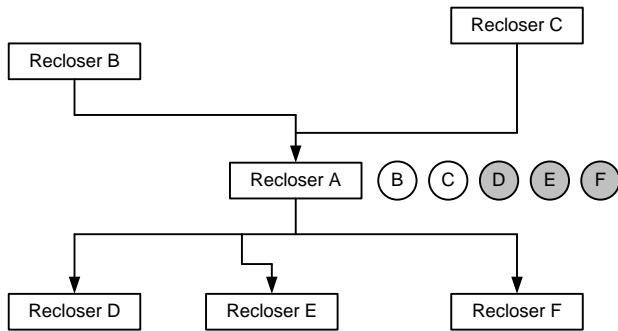

Fig. 9. Typical distribution feeder segment illustrating that trip blocking signals received from Reclosers D, E, and F are passed along to the recloser control.

If the flow of power were to be reversed, trip blocking signals from Reclosers B and C should be passed along, while signals from Reclosers D, E, and F should be ignored.

B. Making Each GOOSE Message Unique

Each recloser location was assigned a unique identifier based on the geographical coordinates of the pole location. That identifier was set in the logic controller settings inside each cabinet and associated with each recloser device in the FDIR configuration.

Every few seconds, the FDIR system recalculates the topology. If anything has changed, it writes an analog value out to each recloser cabinet. This analog is the unique identifier of the nearest upline protection device in the new feeder topology. The GOOSE data set transmitted by each logic controller contains an analog and a digital object. The digital object is the blocking signal value itself. The analog object is set to the unique identifier of the upline recloser as received by the FDIR system. When a logic controller receives a blocking signal, it compares the value of the analog object in the received data set to its own unique identifier. If the two values are equivalent, the blocking signal is forwarded to the recloser control. The logic controllers described in the test setup earlier in this section performed this comparison.

This blocking scheme design allows for distribution system flexibility in an elegant manner. Instead of the creation of a series of if-then logic rules for each recloser that are rigid and do not adapt well to changes or additions of lines or devices, the FDIR system real-time knowledge of the distribution system topology is put to work in such a way that maintaining the system takes minimum effort. There are, of course, configuration tasks that must be performed whenever a new device or line is added to the system. The FDIR system must be made aware of the new device, and the system GOOSE configuration must be modified in all of the devices

affected by the new addition. These tasks, however, would exist with any implementation of a trip blocking scheme that required logic in the recloser cabinets. The maintenance advantage that this solution provides is that a minimum of logic changes and design need be performed. The modifications are more routine, and a fixed documented procedure is more simply defined.

V. CONCLUSION

This paper discusses the implementation of several technologies: FDIR, volt/VAR control, and system-wide IEC 61850 GOOSE-based trip blocking. While none of these technologies are new, the collaborative manner in which they were implemented is new. This paper serves to illustrate the advantages of having systems that can be aware of the entire distribution system. There is always a balance to be found between centralized and distributed intelligence as DA becomes more prevalent, and that balance should be discovered by leveraging the usefulness of centralized knowledge while sacrificing as little of the inherent redundancy that comes with distributed intelligence as possible. These systems are not difficult to design in a complex or rigid manner, but making an elegant and dynamic solution capable of reacting to an ever-changing distribution system is a much greater challenge.

The City of Wadsworth is a good example of what can be accomplished when a high-speed communications network is leveraged throughout the course of a complete P&C system upgrade. While this type of project does not take place every day, opportunities like this allow the DA world to design new methods of monitoring and control, while providing a higher quality of service to the customer.

VI. ACKNOWLEDGMENT

This material is based upon work supported by the Department of Energy under Award Number DOE – OE0000280.

Disclaimer: This report was prepared as an account of work sponsored by an agency of the United States Government. Neither the United States Government nor any agency thereof, nor any of their employees, makes any warranty, express or implied, or assumes any legal liability or responsibility for the accuracy, completeness, or usefulness of any information, apparatus, product, or process disclosed, or represents that its use would not infringe privately owned rights. Reference herein to any specific commercial product, process, or service by trade name, trademark, manufacturer, or otherwise does not necessarily constitute or imply its endorsement, recommendation, or favoring by the United States Government or any agency thereof. The views and opinions of authors expressed herein do not necessarily state or reflect those of the United States Government or any agency thereof.

VII. REFERENCES

- [1] E. T. Jauch, "Volt/VAR Management – An Essential 'SMART' Function," proceedings of the IEEE/PES Power Systems Conference and Exposition, Seattle, WA, March 2009.
- [2] K. P. Schneider, J. C. Fuller, F. K. Tuffner, and R. Singh, *Evaluation of Conservation Voltage Reduction (CVR) on a National Level*, Pacific Northwest National Laboratory, Technical Report PNNL-19596, July 2010.
- [3] B. Kasztenny, J. Whatley, E. A. Udren, J. Burger, D. Finney, and M. Adamiak, "IEC 61850: A Practical Application Primer for Protection Engineers," proceedings of the 60th Annual Georgia Tech Protective Relaying Conference, Atlanta, GA, May 2006.

VIII. BIOGRAPHIES

Mark Feller, P.E. received his BSEE from the University of Cincinnati. He has over 35 years of experience in the electric power industry and has been with City of Wadsworth Electric and Communications Department since 1995, where he is currently Communications, Substation and Project Superintendent, managing 25 employees. Mr. Feller has overall responsibility for planning, design, and construction management of system improvements. He is also responsible for system studies and long-term planning, system protection, SCADA, and resolution of power quality issues. Mr. Feller directs the substation maintenance program and Communications Department, which has operated a fiber backbone since 1994, providing PAC communication. He also operates an HFC network for the City of Wadsworth's commercial high-speed Internet and CATV systems.

Mr. Feller was a founding partner of PFK Consulting Engineers. He has prior experience with an investor-owned electric utility and in high-voltage electrical equipment manufacturing. Mr. Feller has been a registered professional engineer in Ohio since 1983.

Bryan Fazzari received his BSEE from the University of Idaho in 2010. He joined Miriam Technologies, Inc. as an associate programmer in 2003, where he developed object-oriented web applications for four years. Mr. Fazzari joined Schweitzer Engineering Laboratories, Inc. (SEL) in 2007 as an intern in the research and development division, focusing primarily on synchrophasor-related software development. In 2010, he transferred to the SEL engineering services division, where he works as an automation engineer.

Robert Van Singel received his BSEE and MSEE degrees from Michigan Technological University in 2008 and 2010, respectively. He joined Schweitzer Engineering Laboratories, Inc. (SEL) in 2009 as an intern in the sales and customer service division. After completion of his masters degree in 2010, Mr. Van Singel joined the SEL engineering service division as a protection engineer. In 2011, he changed focus and currently works as an automation engineer.

William C. Edwards Jr. received his BSEE from the Georgia Institute of Technology in 2011. He joined Schweitzer Engineering Laboratories, Inc. (SEL) in 2011, where he is presently an automation engineer. Prior to joining SEL, Mr. Edwards worked for the Nanotechnology Research Center, where he designed and constructed an autonomous plasma-enhanced chemical vapor deposition machine used for polymer lithographic printing. He is a member of IEEE.